

GENERAL POINTS

L.V. distribution	D. 4
Communication networks	D. 12

WIRING SYSTEMS

Overload currents	D. 14
Short circuit currents	D. 20
Direct and indirect contacts	D. 27

DEVICES

Switching devices	D. 34
UL and NEMA specifications	D. 40
Fuses	D. 44
Energy management	
DIRIS and COUNTIS	D. 55
Measuring	D. 59
Differential protection	D. 61
Insulation monitoring device	D. 66
Enclosures	D. 71
Busbars	D. 73

APPLICATION GUIDE

L.V. distribution

Earthing arrangements

An earthing, or "neutral load" arrangement on an LV network is defined by two letters:

The first defines the earth connection of the transformer's secondary (in most cases neutral)		The second defines the masses connection to earth.	
earthed	T	T	earthed
insulated from earth	I	T	earthed
earthed	T	N	connected to neutral

Earthing arrangements define the principles of distribution, and also ensure protection against indirect contact by automatically cutting off the power supply.

TT: "neutral to earth" load

Use of this type of load is generally stipulated by the electricity board. Should there be an insulation fault, all or part of the operational equipment is cut off.

Cut off is obligatory at first fault.

The operational equipment must be fitted with instantaneous differential protection.

Differential protection can be general or subdivided according to the type and size of the installation.

This type of load can be found in the following contexts: domestic, minor tertiary, small workshops/processes, educational establishments with practical workshops, etc.

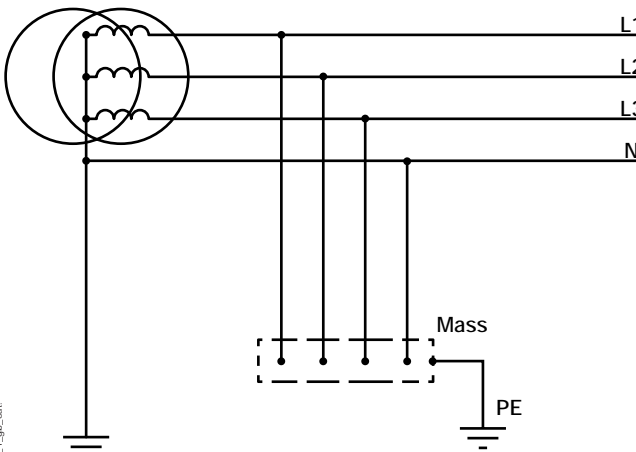

Fig. 1: TT arrangement

TN: "neutral connection" load

This distribution principle is suited to all networks which have a cut off system at first fault.

Installing and operating this type of network is economical but requires rigorous general circuit protection.

Neutral (N) and protective (PE) conductors can be common (TNC) or separated (TNS).

TNC arrangement

The protective and neutral conductor (PEN) must never be sectioned. Conductors must have a section over 10 mm² in copper and over 16 mm² in aluminium, and must not include mobile installations (flexible cables).

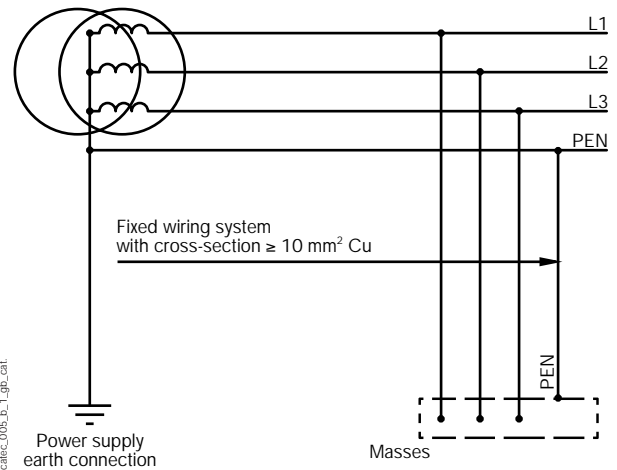

Fig. 2: TNC arrangement

Note: In order to avoid current circulating in the mass, the mass must be connected directly to the PEN terminal (and not the opposite). See fig. 3

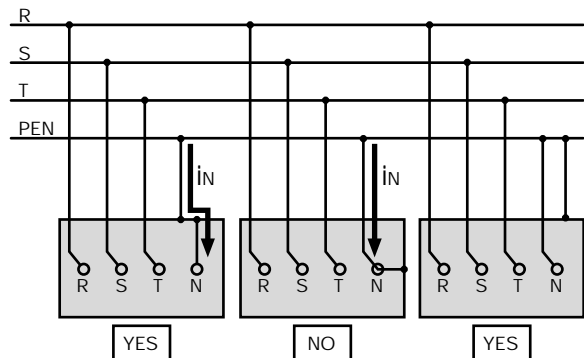

Fig. 3: correct connection of PEN

Earthing arrangements (continued)

► TN: "neutral connection" load (continued)

TNS arrangement

A TNS network can be set up upstream of a TNC network, where as the opposite is forbidden.

Neutral TNS conductors are generally sectioned, unprotected, and have the same sections as the corresponding phase conductors.

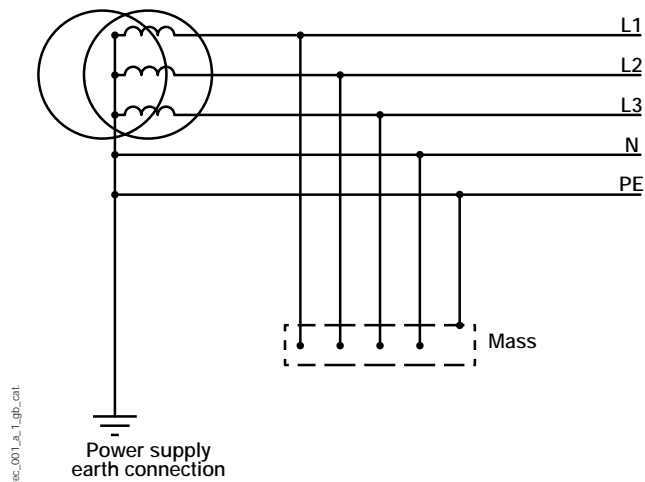

Fig. 1: TNS arrangement

► IT: "insulated neutral" load

This neutral load is used when first fault cut off is detrimental to correct operation or personnel safety.

Implementing this type of installation is simple, but requires qualified personnel on-site to intervene quickly when a faulty insulation is detected.

An overvoltage limiter is compulsory to enable overvoltage caused by HV installations (such as HV/LV transformer breakdown, operations, lightning, etc.), to flow to earth.

Personnel safety is ensured by:

- interconnecting and earthing of masses,
- monitoring first fault by IMD (Insulation Monitoring Device),
- using second fault cut off by overcurrent protection devices, or by differential devices.

This system can be found, for example, in hospitals (operating theatres), or in safety circuits (lighting) and in industries where continuity of operations is essential or where the weak default current considerably reduces the risk of fire or explosion.

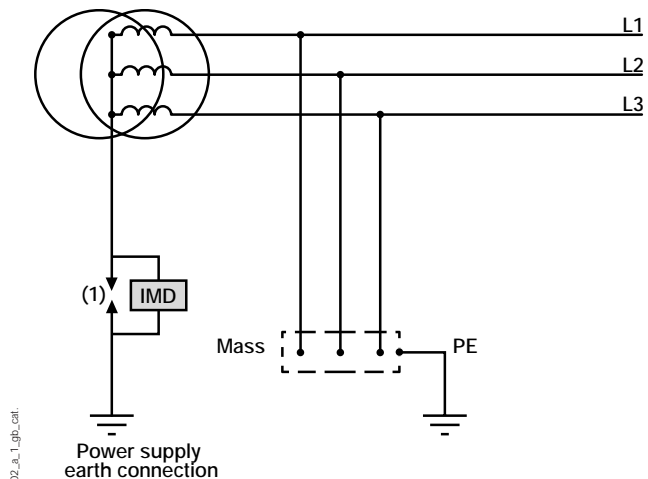

(1) Over voltage limiter

Fig. 2: IT arrangement without distributed neutral

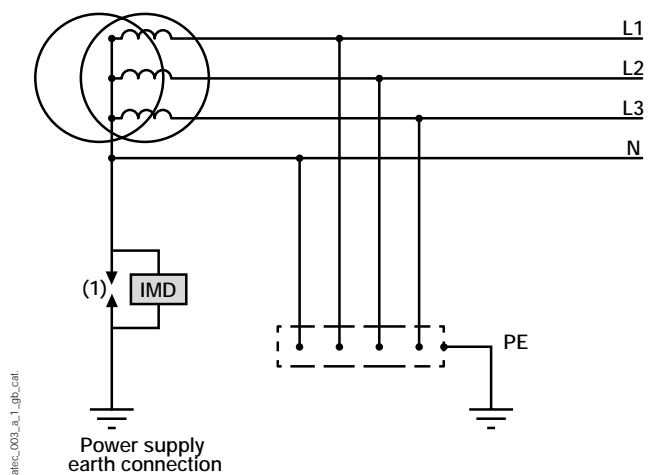

(1) Over voltage limiter

Fig. 3: IT arrangement with distributed neutral

L.V. distribution

Voltages, overvoltages

▶ Voltage range

In LV, two ranges can be identified according to IEC 364 standard.

RANGE	NOMINAL VOLTAGE U_n	
	AC	DC
ELV: Extra Low Voltage	≤ 50 V	≤ 120 V
LV: Low Voltage	50 V < $U_n \leq 1000$ V	120 V < $U_n \leq 1500$ V

▶ Standard AC voltages

- Single phase: 230 V
- Three phase: 230 V / 400 V and 400 V / 690 V
- Present tolerance: +6% / -10%

Voltage and tolerance development (IEC 60 038)

PERIOD	VOLTAGE	TOLERANCE
Before 1983	220 V / 380 V / 660 V	$\pm 10\%$
From 1983 to 2003	230 V / 400 V / 690 V	+6% / -10%
After 2003	230 V / 400 V / 690 V	$\pm 10\%$

▶ U_i insulation voltage

This describes the device's maximum operational voltage in normal network conditions

Example: on a 230 V / 400 V network, a device whose insulation voltage $U_i \geq 400$ V must be chosen (see fig. 1).

On a 400 V / 690 V network, a device with insulation voltage $U_i \geq 690$ V must be chosen.

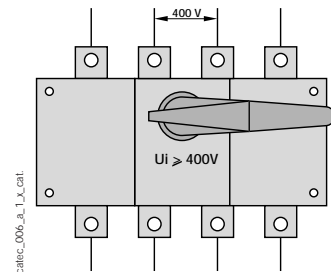

Fig. 1: on 230 V / 400 V networks, devices with insulation voltage ≥ 400 V must be chosen.

▶ 50 Hz dielectric quality

Dielectric quality is defined by the 50 Hz AC voltage which the device can withstand for 1 minute:

- between phases,
- between phase and earth,
- between open poles of the same phase.

This defines the device's withstand to network overvoltage. Overvoltage can result from transformer winding damage, for example, or from HV/LV terminals flashover due to an overvoltage on an HV network. Effective protection consists of connecting the transformer neutral point to earth, passing through an overvoltage limiter.

▶ Dielectric tests

In order to define a device's dielectric insulation quality, IEC 947-3 standard stipulates the following measures:

- U_{imp} withstand on new devices before testing (short-circuits, endurance, etc.),
- verifying dielectric withstand following these tests with $2 \times U_i$ voltage.

▶ U_{imp} impulse withstand voltage

This defines the device's use in abnormal network conditions with overvoltage due to:

- lightning on overhead wires,
- device operating on HV circuits.

This characteristic also defines the device's dielectric quality.

Example $U_{imp} = 8$ kV (see table A).

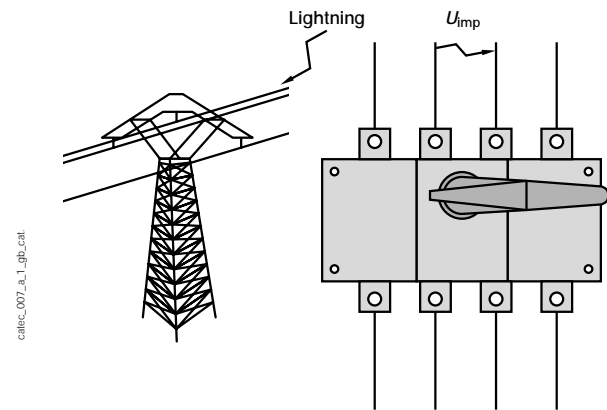

Fig. 2: device withstand to U_{imp}

▶ Overvoltage protection

Overvoltage protection is achieved:

- by choosing the equipment according to U_{imp} . The NF C 15-100 and IEC 60364 standards stipulate 4 categories of use:
 - I specially protected equipment: computers, electronics, etc.,
 - II current-using devices: portable tools, motors, etc.,
 - III equipment placed in distribution networks,
 - IV equipment placed at the head of an installation.

Overvoltage in kV as per utilisation class

THREE-PHASE NETWORK	SINGLE PHASE NETWORK	IV	III	II	I
230 V/400 V	230 V	6	4	2.5	1.5
400 V/690V		8	6	4	2.5

Mains distortion

► Voltage dip and cut-off

Definition

A voltage dip is a decrease of voltage amplitude for a period of time ranging from 10 ms to 1 s. The voltage variation is expressed in percentage of nominal current (between 10% and 100%). A 100% voltage dip is termed a cut-off.

Depending on cut-off time t , the following can be distinguished:

- $10 \text{ ms} < t < 1 \text{ s}$: micro cut-offs due, for example, to fast reset at transient faults, etc.,
- $1 \text{ s} < t < 1 \text{ mn}$: short cut-offs due to protection device operation, switching-in of high start-up current equipment, etc.,
- $1 \text{ mn} < t$: long cut-offs generally due to HV mains.

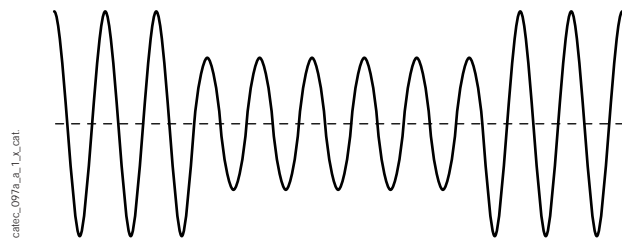

Fig. 1: voltage dip

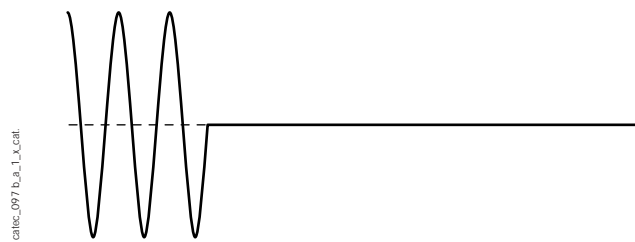

Fig. 2: cut-off

Consequences of voltage dips and cut-offs

- opening of contactors (dip > 30%)
- synchronous motor synchronism loss, asynchronous motor instability
- computer application: data loss, etc.
- disturbance of lighting with gas discharge lamps (quenching when 50% dips for 50 ms, relighting only after a few minutes).

Solutions

- Whatever the type of load:
 - use of a UPS (Uninterruptible Power Supply),
 - modify mains structure (see page D.10).
- Depending on the type of load:
 - supply contactor coils between phases,
 - increase motor inertia,
 - use immediate-relighting lamps.

► Frequency variation

This is generally due to generator set failure. Solution: use of static converter or UPS.

► Flicker

Definition

Light flicker is due to sudden voltage variations, thus producing an unpleasant effect. Sudden voltage variations are due to devices whose consumed power varies quickly: arc furnaces, welding machines, rolling mills, etc.

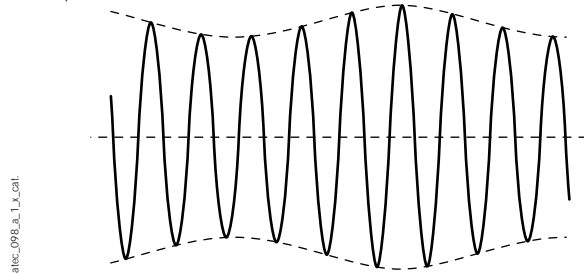

Fig. 3: flicker

Solutions

- UPS (for small loads)
- inductance or capacitor bank in the load circuit
- connection to a specific HV/LV transformer (arc furnaces).

► Transients

Definition

Transient phenomena are essentially fast, very high voltages (up to 20 kV), due to:

- lighting,
- operations or fault on HV mains,
- equipment electric arcs,
- inductive loads switching,
- highly capacitive circuits power on:
 - extended cable systems,
 - machines fitted with anti-stray capacitors.

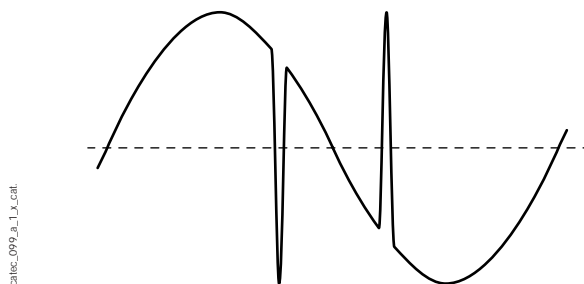

Fig. 4: transient

Transients cause:

- intemperate tripping of protection devices,
- electromagnetic interference,
- insufficiently protected material (electronic components, insulation rupture within motors, etc.).

Solutions

- Following standard IEC 664 for material construction: insulation co-ordination ensuring impulse wave withstand (see page D.6). All SOCOMEC material is manufactured according to this standard
- Use of overvoltage limitors
- Adequate earth connection of HV/LV sets.

Mains distortion (continued)

Harmonics

Definition

Harmonic current or voltage are mains “stray” currents or voltages. They distort the current or voltage wave and lead to the following:

- an increase in current's rms value,
- a current passing the neutral being higher than the phase current,
- transformer saturation,
- disturbance in low current networks,
- intemperate tripping of protection devices, etc.,
- distorted measurements (current, voltage, power, etc.).

Harmonic currents can be caused by current transformers and electric arcs (arc furnaces, welding machines, fluorescent or gas-discharge lamps), but mainly by static rectifiers and converters (power electronics). Such charges are termed non-linear loads (see later).

Harmonic voltage is caused by harmonic current passing through mains and transformer impedance.

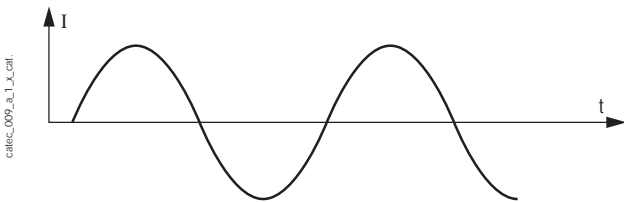

Fig. 1: pure sinusoidal wave current

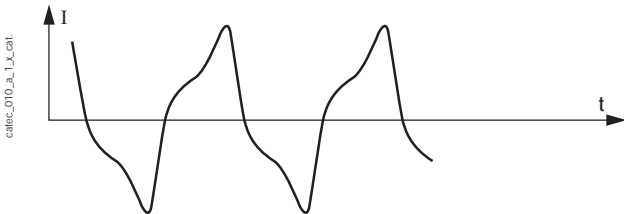

Fig. 2: current distorted by harmonics

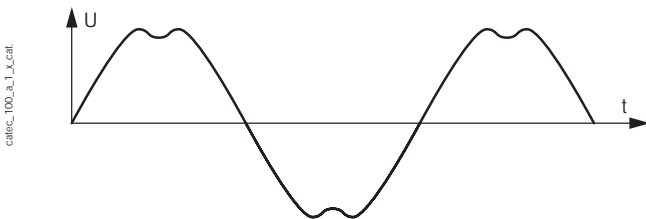

Fig. 3: voltage distorted by harmonics

Solutions

- Supply distorted loads with UPS
- Use of anti-harmonic filters
- Increase conductor cross-section
- Device oversizing.

Linear and non-linear loads

A load is termed linear when current has the same wave-form as voltage:

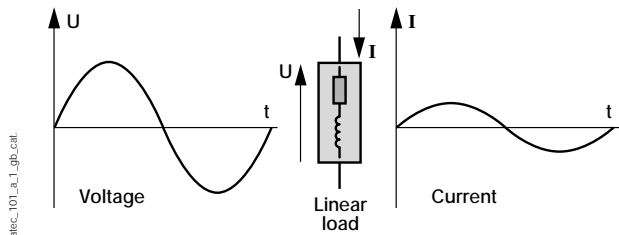

Fig. 4

A load is termed non-linear when the current wave-form no longer corresponds to voltage wave-form:

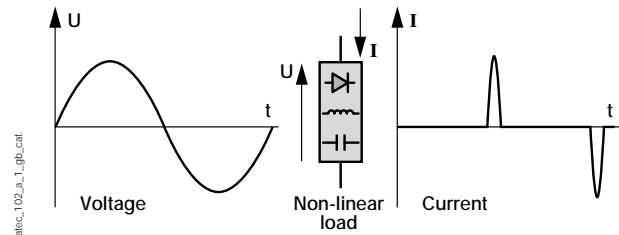

Fig. 5

Non-linear loads to neutral current values which may be much higher than phase current values.

Current peak factor (fp)

With non-linear loads, current distortion can be expressed by peak factor:

$$fp = \frac{I_{peak}}{I_{rms}}$$

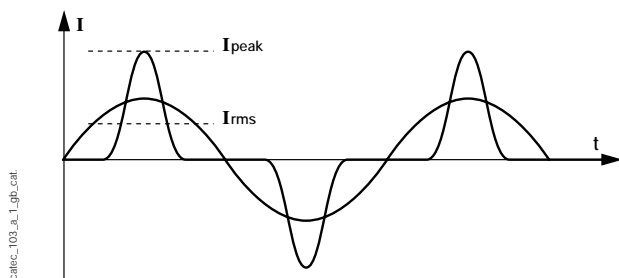

Fig. 6: peak factor: $fp = I_{peak}/I_{rms}$

Examples of fp values:

- resistive charge (pure sinusoidal wave): $\sqrt{2} = 1.414$,
- mainframe computer: 2 to 2.5,
- PC work station: 2.5 to 3,
- printer: 2 to 3.

These few peak factor values show that the current wave can differ greatly from a pure sinusoid.

Mains distortion (continued)

Harmonics

Harmonic number

Harmonic frequencies are multiples of mains frequency (50 Hz). This multiple is called the harmonic number.

Example:

The 5th harmonic current has a frequency of $5 \times 50 \text{ Hz} = 250 \text{ Hz}$.
The 1st harmonic current is called the "fundamental".

Table A: mains harmonic currents

SOURCE	HARMONIC NO	2	3	4	5	6	7	8	9	10	11	12	13	14	15	16	17	18	19	20
Rectifier	1 half wave	•	•	•	•	•	•	•	•	•	•	•	•	•	•	•	•	•	•	•
	2 half waves		•		•		•		•		•		•		•		•		•	
	3 half waves	•		•	•		•	•		•	•		•	•		•	•		•	•
	6 half waves				•		•		•		•		•		•		•		•	
	12 half waves										•		•		•		•		•	
Gas discharge lamp		•		•		•		•		•		•		•		•		•		•
Arc furnace		•		•		•		•		•		•		•		•		•		•

Example: A gas discharge lamp only produces the 3rd, 5th, 7th, 9th, 11th, and 13th harmonic currents. Even-number harmonic currents (2, 4, 6 etc.) are absent.

Measuring device distortion

Ferromagnetic measuring devices (ammeters, voltmeters, etc.) are designed to measure sinusoidal parameters of a given frequency (generally 50 Hz). The same applies to digital devices other than sampling devices. These devices give false readings when the signal is subjected to harmonic distortion (see example below).

Only devices giving true rms values integrate signal distortions and hence give real rms values.

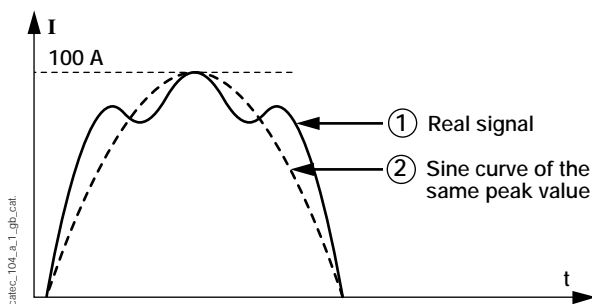

Fig. 1: measurement distortion

Example (fig. 1): signal 1 is distorted by the third harmonic. The rms value of a sine wave with the same peak value would be: $\frac{100 \text{ A}}{\sqrt{2}} = 70 \text{ A}$

The real rms value is 84 A (measured with the relevant device, see DIRIS page D.55).

Calculating rms current

In general, calculating rms current is only done for the first 10 to 20 significant harmonic currents.

Rms current per phase:

$$I_{\text{rms}} = \sqrt{I_n^2 + I_2^2 + I_3^2 + \dots + I_k^2}$$

In: distorter's nominal current

I_2, I_3 , etc.: 2nd, 3rd, etc. harmonic currents.

Mains harmonic currents

The current circulating in the network is the sum of pure sinusoidal current (called "fundamental") and a certain number of harmonic currents, depending on the load type.

On the neutral: odd number harmonic currents, which are also multiples of 3 are added together:

$$I_{\text{Neutral}} = \sqrt{I_{N3}^2 + I_{N9}^2 + \dots}$$

$$I_{N3} = 3I_3$$

$$I_{N9} = 3I_9$$

etc.

The rms values of harmonic currents I_2, I_3 , etc. are difficult to establish. (Please consult us specifying load type, current peak factor, load power and network voltage).

Example:

Calculating phase and neutral current in a network supplied by a double half-wave rectifier.

- Current peak factor: 2.5
- Load 180 kVA → effective current 50 Hz

$$\text{equivalent: } \frac{180 \text{ kVA}}{\sqrt{3} \times 400 \text{ V}} = 260 \text{ A}$$

- Calculated harmonics: $I_2 = 182 \text{ A } 50 \text{ Hz}$
 $I_3 = 146 \text{ A } 150 \text{ Hz}$
 $I_5 = 96 \text{ A } 250 \text{ Hz}$
 $I_7 = 47 \text{ A } 350 \text{ Hz}$
 $I_9 = 13 \text{ A } 450 \text{ Hz}$

- High range harmonic currents are negligible.

Current in one phase:

$$I_p = \sqrt{(182)^2 + (146)^2 + \dots} = 260 \text{ A}$$

Current in the neutral:

$$I_{\text{Neutral}} = \sqrt{(3 \times 146)^2 + (3 \times 13)^2} = 440 \text{ A}$$

The neutral current is higher than the phase current. Connecting sections, as well as equipment choice, must take this into account.

Distortion and harmonic rates

Overall harmonic rates or distortion rates:

$$T = \frac{\sqrt{I_2^2 + I_3^2 + \dots + I_k^2}}{I_{\text{rms}}}$$

To avoid problems with harmonics, this rate must be less than 5%.
n harmonic rate: n harmonic rms divided by fundamental rms. This must be less than 3%. This definition is also valid for voltage harmonics.

Improving mains quality

Tolerances generally admissible for correct operation of a mains network having loads sensitive to distortion (electronic and computing equipment etc.), are given in the table below:

MAINS PARAMETERS	TOLERANCE
Steady-state voltage (constant load)	±2%
Dynamic-state voltage (variable load)	±10%
Frequency	±1%
Total harmonic rate	< 5%
Maximum harmonic rate	< 3%
Voltage unbalance (three-phase)	< 4%
Phase shift between phase to neutral voltages	120° ±3°
Micro-cut-off	< 10 ms

To achieve these values, substitute sources may be resorted to, and/or precautions taken at the level of installation.

► Substitute sources

The different substitute sources are described in the table below:

SOURCE TYPE	ELIMINATED DISTORTION
Rotating set supplied by mains	<ul style="list-style-type: none"> cut-off < 500 ms (according to flywheel) voltage dip frequency variations
UPS	Effective against all distortion, except long duration cut-offs > 15 mins. to 1 hour (according to installed power and UPS power)
Autonomous generator set	Effective in all cases, but with power supply interrupted during normal/emergency switching (< 2s with a motorised SIRCOVER)
UPS + rotating sets	This solution covers all distortion types

► Installation precautions

Isolate distorting loads:

- with a separate mains, coming from a specific HV input (for high loads),
- by circuit subdivision: a circuit fault should affect other circuits as little as possible,
- by separating circuits consisting of distorting loads. These circuits are separated from other circuits at the highest possible level of the LV installation in order to benefit from disturbance reduction by cable impedance.

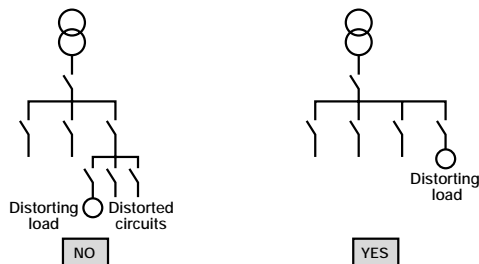

Fig. 1

Choose a suitable earthing system

The IT system guarantees continuous operation, by avoiding, for example, differential device circuit breaking by intemperate tripping following transient disturbance.

Ensure protective devices discrimination

Protective devices discrimination limits circuit fault breaking (see pages D.52 to D.54 and D.63).

Take care over using earth mains:

- by setting up earth mains suitable for certain applications (computing, etc.); each mains being chain-linked to obtain maximum equipotentiality (the lowest resistance between different points of the earth mains),
- by linking these mains in star form, as close as possible to the earthing rod,
- by using interconnected cable trays, chutes, tubes, and metallic gutters connected to earth at regular points,

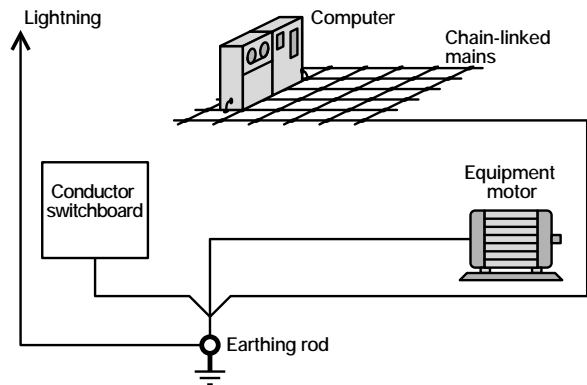

Fig. 2

- by separating distorting circuits from sensitive circuits laid out on the same cable trays,
- by using mechanical earths (cabinets, structures, etc.) as often as possible in order to achieve equipotential masses.

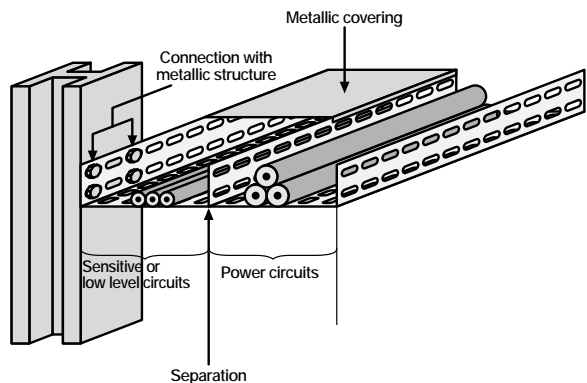

Fig. 3

External influences

Degrees of protection (IP codes)

The degrees of protection are defined by 2 figures and possibly by an additional letter.

For example: IP 55 or IP xx B (x indicates: any value).

The figures and additional letters are defined below:

1 st FIGURE PROTECTION AGAINST SOLID BODY PENETRATION			2 nd FIGURE PROTECTION AGAINST LIQUID PENETRATION			ADDITIONAL LETTER ⁽²⁾	DEGREE OF PROTECTION
IP	Tests		IP	Tests			BRIEF DESCRIPTION
0		No protection	0		No protection		
1	$\varnothing 5.25\text{mm}$	Protected against solid bodies greater than 50 mm	1		Protected against water drops falling vertically (condensation)	A	Protected against access with back of hand
2 ⁽¹⁾	$\varnothing 12.5\text{ mm}$	Protected against solid bodies greater than 12 mm	2		Protected against water drops falling up to 15° from the vertical	B	Protected against access with finger
3	$\varnothing 2.5\text{ mm}$	Protected against solid bodies greater than 2.5 mm	3		Protected against water showers up to 60° from the vertical	C	Protected against access with tool
4	$\varnothing 1\text{ mm}$	Protected against solid bodies greater than 1 mm	4		Protected against water splashes from any direction	D	Protected against access with wire
5		Protected against dust (excluding damaging deposits)	5		Protected against water jets from any hosed direction		
6		Total protection against dust	6		Protected against water splashes comparable to heavy seas		
The first two characterising figures are defined in the same way by NF EN 60 529, IEC 529 and DIN 40 050			7	1m 15cm mini	Protected against total immersion		

Note:

(1) Fig. 2 is established by 2 tests:

- non penetration of a sphere with the diameter of 12.5 mm,
- non accessibility of a test probe with a diameter of 12 mm.

(2) This additional letter only defines the access to dangerous components

Example: A device has an aperture allowing access with a finger. This will not be classified as IP 2x. However, if the components which are accessible with a finger are not dangerous (electric shock, burns, etc.), the device will be classified as xx B.

Protection levels against mechanical shock

A third figure may added to the IP code. This figure defines the protection index against mechanical shock. The third figure has been replaced by the IK index (EN 50102, NF C 20015).

IP/IK correspondence (subject to definitive standard)

Shock energy (J)	0	0.15	0.2	0.225	0.35	0.375	0.5	0.7	1	2	5	6	10	20
3 rd IP figure	-	-	-	1	-	2	3	-	-	5	-	7	-	9
IK index	0	1	2		3		4	5	6	7	8		9	10
Classification AG (IEC 60 364)				AG1						AG2		AG3		AG4

Communication networks

Digital communication

General points

A communication network interconnects a certain number of devices (electrical or computing), in order to exchange information: commands, measurements, etc. Installing a communication network also enables the use of micro-processor technology which considerably improve dialogue between man and machine.

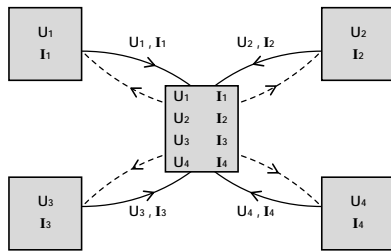

Fig. 1

Transmission definitions

Analogue transmission

The transmitted signal is either a current or a voltage. Example: 0-10 V or 4-20 mA connection.

Digital transmission

The signal is a 0 or 1 binary element called a bit. The information is encoded as a set of bits. Each type of numeric link defines an analog level (voltage level: see table A) with 0 and 1 logic at input and output.

Serial and parallel link

With a serial link, the set of bits comprising the information is transmitted on the same cable (in series) one after the other. This link requires two cables and an earth wire, or just two wires. With a parallel link, each bit is sent via a different wire. For an 8-bit encoding, a minimum of 8 wires plus one earth wire will therefore be necessary.

Sending/receiving

Transmission consists of sending and receiving. These can be:

- separated on two distinct channels (4-cable simplex link plus earth for an RS 485)
- together on one channel, sending and receiving performed alternately in both directions (two-cable half duplex + earth)
- together on one channel, sending and receiving performed simultaneously (two-cable full duplex).

Bit rate

This is the number of bits a link is able to transmit in 1 second, characterised by a unit: the baud (Bd).

For numeric links which concern us 1 baud = 1 bit per second.

Channel

The simplest channel consists of two sheathed twisted cables (telephone pair), but coaxial cables, optic fibres or radio transmission are also possible. The channel depends on the chosen transmission type.

Range

The range is the maximum distance between an emitter and a receiver ensuring correct transmission of a signal.

Example: RS485 = 1500 m to 9600 bauds.

Example

Transmitting information resulting from the measurement: $U = 230\text{ V}$

- Solution 1:** by analog transmission. The value 230 V is equivalent to a current of 10 mA (for example).

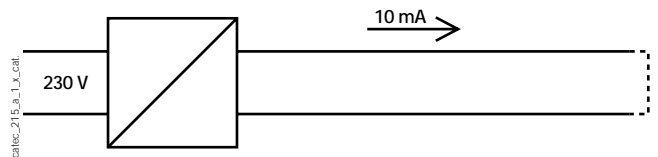

- Solution 2:** digital transmission. The value 230 V is encoded on a set of bits giving the message $U = 230\text{ V}$. In our example coding is done with 8 bits: $230\text{ V} = 00100110$

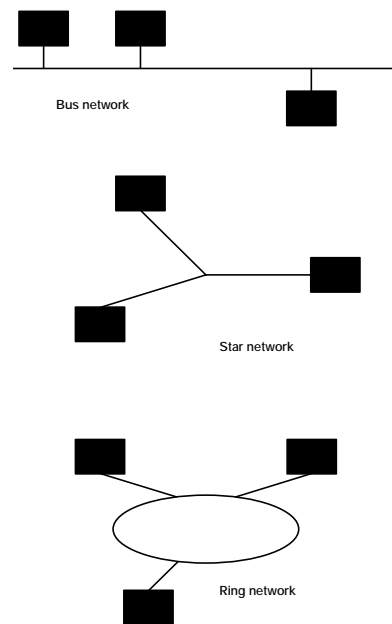
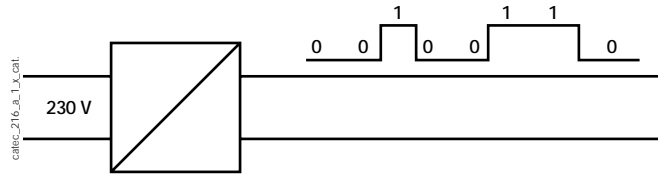

Fig 2 : network topology

Table A: comparison of RS232, RS485, RS422 links and current loop

BUS	CURRENT LOOP	RS232-C	RS422-A	RS485
Max. speed (bauds)	9.6 k	19.2 k	10 M	10 M
Number of transmitters	multipoint	1	1	1
Number of receivers	multipoint	1	10	31 receivers
Max. distance (m)	3000	15	1500 ⁽¹⁾	1500 ⁽¹⁾
Transmission voltage	0	from +5 to +15 V	from +2 to +6 V	from +5 to +15 V
	1	20 mA	from -2 to -6 V	from -5 to -15 V
Receiving threshold	0	5 mA	> +0.2 V	> +0.2 V
	1	10 mA	< -0.2 V	< -0.2 V

(1) 1500 m a 9600 bauds.

Communication networks (continued)

Protocols

Communication between several devices requires a common structure and language: this is known as the protocol.

Each type of link (JBUS/MODBUS, BATIBUS, EIBUS, etc.) has its own protocol defined by certain standards. However, all protocols are subdivided into 7 levels called layers. Each layer receives elementary information from the lower layer, processes it, and then supplies more elaborated information to the upper layer. DIRIS system uses layers 1, 2 and 7 only.

Layer 1: physical layer

The physical layer is the protocol's elementary layer. It defines the transmission mode, the medium (cable, etc.) and the network topology. Layer 1 (RS 232, RS 485) is defined by IUT Standards (International Union of Telecommunications).

Layer 2: link layer

This controls network access (e.g. master/slave system), the addressing control (emitter or receiver identity) and checking transmission errors.

Layer 3: networks

This layer is defined by the addressing, the path or the performances of the system.

Layer 4: transport

This layer provides point to point communication between the transmitter and the receiver and monitors its quality.

Layer 5: session

This controls flows and storage in the memory.

Layer 6: presentation

This layer provides the transcoding, the format, the conversion and the encoding.

Layer 7: application layer

The application layer consists of the highest information level and enables communication with the system user.

The protocol must be chosen according to the application. The distance between the master and the slaves, the number of products on the link and the current network are so many parameters which will be considered when making the choice. Today there are several possible solutions:

The standard solutions

- for not very complex transmissions between different input and output units, protocols like Can or ASI can be used (example: link between products in the same range)
- for transmissions between one or more actuators or sensors with PCs or PLCs, protocols such as INTERBUS-S®, PROFIBUS® or JBUS/MODBUS® can be used.
- for transmissions between PCs or between PCs and PLCs, industrialists are increasingly using the ETHERNET network with its TCP-IP protocol. In certain cases, by using specific interfaces, actuators are connected directly onto Ethernet from specific interfaces.

Specific solutions

There are also protocols that are specific to certain manufacturers. The latter generally propose gateways allowing the conversion of their protocol into a standard protocol of the JBUS/MODBUS® type, for example.

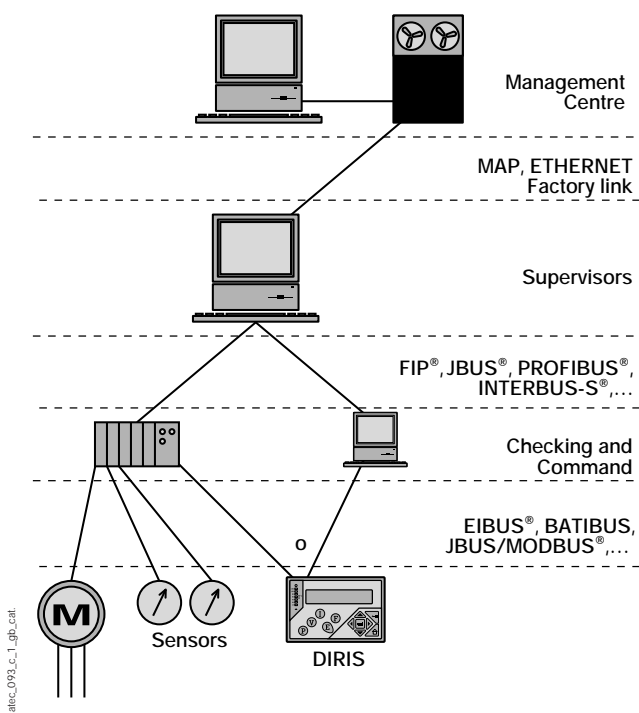

Fig. 1: example of industrial network

Overload currents

Co-ordination between conductors and protective devices

Definition

Protective devices shall be provided to break any overload current flowing in the circuit conductors before such a current could cause a temperature rise detrimental to insulation, joints, terminations, or surroundings of the conductors (IEC 364).

To do this, the following currents are defined:

- **I_b**: current for which the circuit is designed
- **I_z**: continuous current-carrying capacity of the cable
- **I_n**: nominal current of the protective device
- **I₂**: current ensuring effective operation of the protective device; in practice I₂ is taken as equal to:
 - the operating current in conventional time for circuit breakers
 - the fusing current in conventional time for type gG fuses.

Conductors are protected if these two conditions are met:

1: $I_b \leq I_n \leq I_z$
2: $I_2 \leq 1.45 I_z$

Example

Supplying a 150 kW load on a three-phase 400 V network.

I_b = 216 A current necessary for the load

I_n = 250 A gG fuse rating protecting the circuit

I_z = 298 A maximum admissible current for a 3 x 95 mm² cable complying with installation method, and the external conditions defined by the method presented in the pages to follow

I² = 400 A 250 A fuse melting current (1.6 x 250 A = 400 A)

1.45 I_z = 1.45 x 293 = 425 A

Conditions 1 and 2 have been satisfactorily met:

I_b = 216 A ≤ I_n = 250 A < I_z = 298 A

I² = 400 A ≤ 1.45 I_z = 432 A.

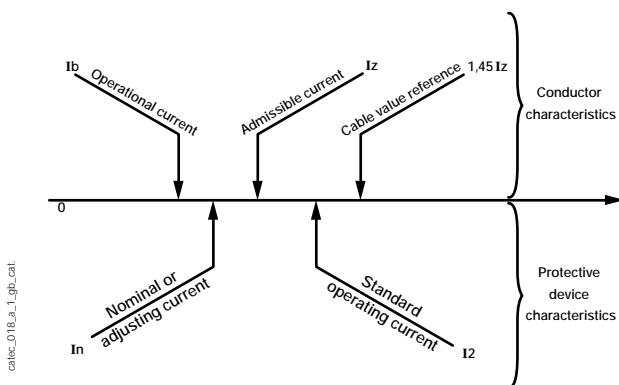

Fig. 1: co-ordination between conductors and protective devices

Defining I₂ current

This is the current which ensures effective protective device operating:

PROTECTION TYPE	I ₂ CURRENT
gG fuse (IEC 269-2-1)	
Rating ≤ 4 A	2.1 I _n
4 A < Rating < 16 A	1.9 I _n
Rating ≥ 16 A	1.6 I_n
Industrial circuit breaker	1.45 I _n
DIRIS CP or P/PS	1.15 I ₀

Defining I_z currents (according to IEC 364)

► Continuous current - Carrying capacity of cables

Table A gives maximum I_z current value for each copper and aluminium cable section. These values must be corrected according to the following coefficients:

- K_m: installation method coefficient (page D.16)
- K_n: coefficient taking into account the number of cables laid together
- K_t: coefficient taking into account ambient air temperature and cable type.

Coefficients K_m, K_n, and K_t, are defined according to cable installation categories: B, C, E, or F (see pages D.16 and D.17).

The chosen section must be:

$$I_z \geq I'_z = \frac{I_b}{K_m \times K_n \times K_t}$$

Cables are classified in two families: PVC and PR (see table on p. D.22). The following figure gives the number of loaded cables. Cables insulated with elastomere (rubber, butyl, etc.) are classified in family PR.

Example: PVC 3 indicates a cable from the PVC category with 34 loaded conductors (3 phases or 3 phases + neutral).

Table A

Category	Maximum I _z current in conductors (A)								
	B	PVC3	PVC2	PR3	PR2	PR2	PR2	PR2	PR2
S in mm² copper									
1.5	15.5	17.5	18.5	19.5	22	23	24	26	
2.5	21	24	25	27	30	31	33	36	
4	28	32	34	36	40	42	45	49	
6	36	41	43	48	51	54	58	63	
10	50	57	60	63	70	75	80	86	
16	68	76	80	85	94	100	107	115	
25	89	96	101	112	119	127	138	149	161
35	110	119	126	138	147	158	169	185	200
50	134	144	153	168	179	192	207	225	242
70	171	184	196	213	229	246	268	289	310
95	207	223	238	258	278	298	328	352	377
120	239	259	276	299	322	346	382	410	437
150		299	319	344	371	395	441	473	504
185		341	364	392	424	450	506	542	575
240		403	430	461	500	538	599	641	679
300		464	497	530	576	621	693	741	783
400					656	754	825		940
500					749	868	946		1083
630					855	1005	1088		1254
S in mm² aluminium									
2.5	2.5	16.5	18.5	19.5	21	23	24	26	28
4	22	25	26	28	31	32	35	38	
6	28	32	33	36	39	42	45	49	
10	39	44	46	49	54	58	62	67	
16	53	59	61	66	73	77	84	91	
25	70	73	78	83	90	97	101	108	121
35	86	90	96	103	112	120	126	135	150
50	104	110	117	125	136	146	154	164	184
70	133	140	150	160	174	187	198	211	237
95	161	170	183	195	211	227	241	257	289
120	188	197	212	226	245	263	280	300	337
150		227	245	261	283	304	324	346	389
185		259	280	298	323	347	371	397	447
240		305	330	352	382	409	439	470	530
300		351	381	406	440	471	508	543	613
400					526	600	663		740
500					610	694	770		856
630					711	808	899		996

Overload currents

Defining I_z currents (continued)

► Km coefficient

According to IEC 364 standard: (Table A)

CAT	METHOD OF INSTALLATION	Km				
		(a)	(b)	(c)	(d)	
B	1 In thermally insulating wall	0.77	-	0.70	0.77	
	2 Visible assembly, embedded in wall or raised section	1	-	0.9	-	
	3 In building construction cavities/spaces or false ceilings	0.95	-	0.865	0.95	
	4 In cable troughs	0.95	0.95	-	0.95	
	5 In chutes, mouldings, skirting or baseboards	-	1	-	0.9	
C	1 mono or multi-conductor cables embedded directly in a wall without mechanical protection	-	-	-	1	
	2 • Wall-fixed cables • Ceiling-fixed cables	-	-	1	0.95	
	3 Open-mounted or insulated conductors	-	1.21	-	-	
	4 Cables mounted on non-perforated cable trays	-	-	-	1	
E F	Multi or monoconductor cables on	{ 1 - perforated cable trays 2 - brackets, ladders 3 - Wall-jutting clamps 4 - Suspended cables on suspension cable	-	-	-	1

(a) Insulated conductor placed in a conduit
(d) Cable not placed in a conduit

(b) Insulated conductor not placed in a conduit

(c) Cable placed in a conduit

► Kn coefficient

According to IEC 364 standard:

Table A

CATEGORY	JOINED CABLE LAYOUT	Kn CORRECTIVE FACTORS											
		N° OF CIRCUITS OR MULTICONDUCTOR CABLES											
		1	2	3	4	5	6	7	8	9	12	16	20
B, C	Embedded or sunk in to walls	1.00	0.80	0.70	0.65	0.60	0.55	0.55	0.50	0.50	0.45	0.40	0.40
C	Single layer on walls or flooring or non perforated racks	1.00	0.85	0.79	0.75	0.73	0.72	0.72	0.71	0.70	No additional reduction factor for more than 9 cables		
	Single layer onto ceiling	0.95	0.81	0.72	0.68	0.66	0.64	0.63	0.62	0.61			
E, F	Single layer on horizontal perforated racks or vertical racks	1.00	0.88	0.82	0.77	0.75	0.73	0.73	0.72	0.72			
	Single layer on cable ladders, brackets, etc	1.00	0.88	0.82	0.80	0.80	0.79	0.79	0.78	0.78			

When cables are laid out in several layers the Kn value must be multiplied by:

Table B

N° of layer	2	3	4 and 5	6 to 8	9 or more
Coefficient	0.80	0.73	0.70	0.68	0.66

Example

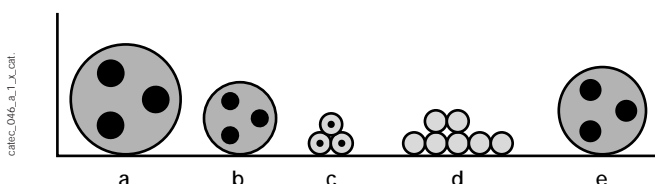





















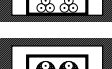

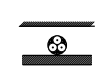

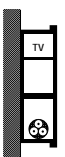
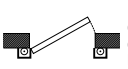
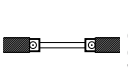
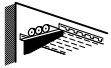
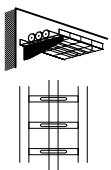

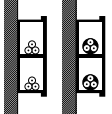
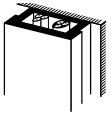
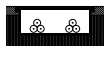
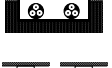
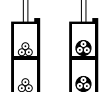
The following are laid out on a perforated rack:

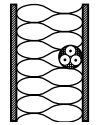
- 2 three-pole cables (2 circuits a and b)
- 1 single-pole three-cable set (1 circuit, c)
- 1 set made up of 2 conductors per phase (2 circuits, d)
- 1 three-pole cable for which Kn must be defined (1 circuit, e)

The total number of circuits is 6. The reference method is method E (perforated rack). Kn = 0.57.

Defining Iz currents (continued)

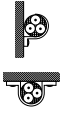
Method of installation

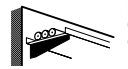
<p>• B - 1 category</p>  Insulated conductors in embedded conduits within thermally insulating walls.  Multiconductor cables in embedded conduits within thermally insulating walls.  Insulated conductors in visibly-assembled conduits.  Mono or multi-conductor cables in visibly-assembled conduits  Insulated conductors in visibly-assembled raised-section conduits.  Mono or multi-conductor cables in visibly-assembled raised-section conduits.  Insulated conductors in conduits embedded in walls.  Mono or multi-conductor cables in conduits embedded in walls.	<p>• B - 3 category</p>  Mono or multi-conductors in building construction cavities.  Insulated conductor in building construction cavities.  Mono or multi-conductor cables in section conduits in building construction cavities.  Insulated conductors in section conduits in building construction cavities.  Mono or multi-conductor cables in section conduits building construction cavities.  Insulated conductors in section conduits embedded in construction.  Mono or multi-conductor cables in section conduits embedded in construction. Mono or multi-conductor cables: - in false ceilings, - in suspended ceilings.	<p>• B - 5 category</p>  Insulated conductors in mouldings.  Insulated conductors or mono or multi-conductors in grooved skirting or base-boards.  Insulated conductors in conduits or mono or multi-conductor cables in jamb linings.  Insulated conductors in conduits or mono or multi-conductor cables in window frames.	<p>• E - 1⁽¹⁾ and F - 1⁽²⁾ categories</p>  On perforated cable trays or racks, horizontal or vertical path. <p>• E - 2⁽¹⁾ and F - 2⁽²⁾ categories</p>  - on brackets, - on cable ladders. <p>• E - 3⁽¹⁾ and F - 3⁽²⁾ categories</p>  Wall-jutting clamp-fixed. <p>• E - 4⁽¹⁾ and F - 4⁽²⁾ categories</p>  Mono or multi-conductor cables suspended on suspension or self-supporting cable.
<p>• B - 2 category</p>  Insulated conductors or mono or multi-conductor cables in wall-fixed chutes: - horizontal path  - vertical path  Insulated conductors in chutes embedded in floors.  Mono or multi-conductor cables in chutes embedded in floors  Insulated conductors in suspended chutes  Mono or multi-conductor cables in suspended chutes.	<p>• B - 4 category</p>  Multi-conductor cables directly embedded in thermally insulating walls.  Insulated conductors in conduits or multi-conductor cables in closed cable troughs, vertical or horizontal path.  Insulated conductors in conduits in ventilated cable troughs.  Mono or multi-conductor cables in open or ventilated cables troughs.	<p>• C - 1 category</p>  Mono or multi-conductor cables directly embedded in walls, without any extra mechanic protection.  Mono or multi-conductor cables directly embedded in walls with an extra mechanic protection.	<p>• C - 2 category</p>  Mono or multi-conductor cables with or without sheathing. - wall-fixed cables, - ceiling-fixed cables. <p>• C - 3 category</p>  Open-mounted or insulated on insulator conductors. <p>• C - 4 category</p>  Mono or multi-conductor cables on non-perforated cable trays or racks.

Kf coefficient

According to IEC 364 standard:

Table C

AMBIENT TEMPERATURE (°C)	INSULATION		
	ELASTOMER (RUBBER)	PVC	PR/EPR
10	1.29	1.22	1.15
15	1.22	1.17	1.12
20	1.15	1.12	1.08
25	1.07	1.06	1.04
35	0.93	0.94	0.96
40	0.82	0.87	0.91
45	0.71	0.79	0.87

AMBIENT TEMPERATURE (°C)	INSULATION		
	ELASTOMER (RUBBER)	PVC	PR/EPR
50	0.58	0.71	0.82
55	-	0.61	0.76
60	-	0.50	0.71
65	-	-	0.65
70	-	-	0.58

Example: For an insulated PVC cable where the ambient temperature reaches 40 °C, then $K_t = 0.87$.

Overload currents

Defining I_z current (continued)

► Cable identification

Table A:
Equivalence between the old and the new name (cables)

OLD NAME (NATIONAL STANDARD) (NATIONAL STANDARD)	NEW NAME (HARMONISED STANDARD)
U 500 VGV	A 05VV - U (o R)
U 1000 SC 12 N	H 07 RN - F
U 500 SV 0V	A 05 VV - F
U 500 SV 1V	

Table B: cable classification

PR CABLES		PVC CABLES	
U 1000	R 12 N	FR-N 05	W-U, R
U 1000	R2V	FR-N 05	W-AR
U 1000	RVFV	FR-N 05	VL2V-U, R
U 1000	RGPFV	FR-N 05	VL2V-AR
H 07	RN-F	H 07	VVH2-F
FR-N 07	RN-F	H 07	VVD3H2-F
A 07	RN-F	H 05	VV-F
FR-N 1	X1X2	H 05	VVH2-F
FR-N 1	X1G1	FR-N 05	VV5-F
FR-N 1	X1X2Z4X2	FR-N 05	VVC4V5-F
FR-N 1	X1G1Z4G1	A 05	VV-F
FR-N 07	X4X5-F	A 05	VVH2-F
0.6/1	twisted		
FR-N 1	XDV-AR, AS, AU		
H 05	RN-F		
A 05	RN-F		
H 05	RR-F		
A 05	RR-F		

► Examples

Example 1

A three-phase load with neutral and 80 A nominal current, is to be supplied (therefore I_b = 80 A). Cable type U 1000 R2V is used on a perforated rack with three other circuits at an ambient temperature of 40 °C. Which section should be chosen?

I_z must be:

$$I_z > I'_z = \frac{I_b}{K_m \times K_n \times K_t}$$

- Defining I'_z
 - method of installation: "E", therefore K_m = 1 (see table A p. D.17)
 - total number of circuits: 4, therefore K_n = 0.77 (see table A p. D.16)
 - ambient air temperature: 40 °C, therefore K_t = 0.91 (see table C p. D.17).

$$\text{Therefore } I'_z = \frac{80 \text{ A}}{1 \times 0.77 \times 0.91} = 114 \text{ A}$$

- Defining I_z
 - Cable U 1000 R2V has a PR classification (see table B). The number of charged conductors is 3. Turn to table A on page D.55 and find column PR3 corresponding to category E. The I_z value immediately higher than I'_z must be chosen, therefore I_z = 127 A, this corresponding to a 3 x 25 mm² copper cable, protected by a 100 A gG fuse, or a 3 x 35 mm² aluminium cable, protected by a 100 A gG fuse.

Example 2

The I₀ adjusting current for a DIRIS CP protecting a 3-phase + neutral circuit is defined in the following conditions:

- single conductor copper cables, with PR insulation, laid on brackets
- ambient air temperature: 40 °C
- no other circuits in close proximity
- I_b = 450 A

- Defining I'_z
 - method of installation: "F", therefore K_m = 1 (see table A p. D.16)
 - total number of circuits: 1, therefore K_n = 1 (see table A p. D.16)
 - ambient air temperature: 40 °C, therefore K_t = 0.91 (see table C p. D.17).

$$\text{Therefore } I'_z = \frac{450 \text{ A}}{1 \times 1 \times 0.91} = 494 \text{ A}$$

- Defining I_z and I₀
 - I_z value immediately higher than I'_z: 506 A
 - chosen section: 185 mm².

Fuse protection of wiring systems against overloads

Column I_z gives the maximum admissible current for each copper and aluminium cable cross section according to standard IEC 60 364 and the guide UTE 15-105.

Column F gives the rating of the gG fuse associated with this cross section and type of cable.

Categories B, C, E and F correspond to the different methods of cable installation (see page D.18).

Cables are classified in two families: PVC and PR (see table p. D.18). The figure that follows gives the number of loaded conductors (PVC 3 indicates a cable from the PVC family with 3 loaded conductors: 3 phases or 3 phases + neutral).

Example

A PR3 25 mm² copper cable installed in category E is limited to 127 A and protected by a 100 A gG fuse.

CATEGORY	ADMISSIBLE CURRENT(I _z) ASSOCIATED PROTECTIVE FUSE (F)																	
	PVC3		PVC2				PR3				PR2							
B	PVC3		PVC2				PR3				PR2							
C			PVC3				PVC2		PR3				PR2					
E					PVC3				PVC2		PR3				PR2			
F							PVC3				PVC2		PR3				PR2	
S mm ²																		
COPPER	I _z	F	I _z	F	I _z	F	I _z	F	I _z	F	I _z	F	I _z	F	I _z	F	I _z	F
1.5	15.5	10	17.5	10	18.5	16	19.5	16	22	16	23	20	24	20	26	20		
2.5	21	16	24	20	25	20	27	20	30	25	31	25	33	25	36	32		
4	28	25	32	25	34	25	36	32	40	32	42	32	45	40	49	40		
6	36	32	41	32	43	40	46	40	51	40	54	50	58	50	63	50		
10	50	40	57	50	60	50	63	50	70	63	75	63	80	63	86	63		
16	68	50	76	63	80	63	85	63	94	80	100	80	107	80	115	100		
25	89	80	96	80	101	80	112	100	119	100	127	100	138	125	149	125	161	125
35	110	100	119	100	126	100	138	125	147	125	158	125	171	125	185	160	200	160
50	134	100	144	125	153	125	168	125	179	160	192	160	207	160	225	200	242	200
70	171	125	184	160	196	160	213	160	229	200	246	200	269	160	289	250	310	250
95	207	160	223	200	238	200	258	200	278	250	298	250	328	250	352	315	377	315
120	239	200	259	200	276	250	299	250	322	250	346	315	382	315	410	315	437	400
150			299	250	319	250	344	315	371	315	399	315	441	400	473	400	504	400
185			341	250	364	315	392	315	424	315	456	400	506	400	542	500	575	500
240			403	315	430	315	461	400	500	400	538	400	599	500	641	500	679	500
300			464	400	497	400	530	400	576	500	621	500	693	630	741	630	783	630
400									656	500	754	630	825	630			840	800
500									749	630	868	800	946	800			1083	1000
630									855	630	1005	800	1088	800			1254	1000
ALUMINIUM																		
2.5	16.5	10	18.5	10	19.5	16	21	16	23	20	24	20	26	20	28	25		
4	22	16	25	20	26	20	28	25	31	25	32	25	35	32	38	32		
6	28	20	32	25	33	25	36	32	39	32	42	32	45	40	49	40		
10	39	32	44	40	46	40	49	40	54	50	58	50	62	50	67	50		
16	53	40	59	50	61	50	66	50	73	63	77	63	84	63	91	80		
25	70	63	73	63	78	63	83	63	90	80	97	80	101	80	108	100	121	100
35	86	80	90	80	96	80	103	80	112	100	120	100	126	100	135	125	150	125
50	104	80	110	100	117	100	125	100	136	125	146	125	154	125	164	125	184	160
70	133	100	140	125	150	125	160	125	174	160	187	160	198	160	211	160	237	200
95	161	125	170	125	183	160	195	160	211	160	227	200	241	200	257	200	289	250
120	188	160	197	160	212	160	226	200	245	200	263	250	280	250	300	250	337	250
150			227	200	245	200	261	200	283	250	304	250	324	250	346	315	389	315
185			259	200	280	250	298	250	323	250	347	315	371	315	397	315	447	400
240			305	250	330	250	352	315	382	315	409	315	439	400	470	400	530	400
300			351	315	381	315	406	315	440	400	471	400	508	400	543	500	613	500
400									526	400	600	500	663	500			740	630
500									610	500	694	630	770	630			856	630
630									711	630	808	630	899	800			996	800

Short circuit currents

► **Definition**

A short circuit current is a current triggered by a negligible impedance fault between points of an installation normally having a potential difference.

3 levels of short circuit currents can be identified:

- peak short circuit current (I_{sc} peak) corresponds to the top of the current wave, generating heightened electrodynamic forces, notably at the level of busbars and contacts or equipment connections.
- rms short circuit current (I_{sc} rms): rms value of the fault current which leads to equipment and conductor overheating, and may raise the potential difference of the electrical earth to a dangerous level.
- minimum short circuit current (I_{sc} min): rms value of the fault current establishing itself in high impedance circuits (reduced section conductor and long conductors, etc.). It is necessary to quickly eliminate this type of fault, known as impedant, by appropriate means.

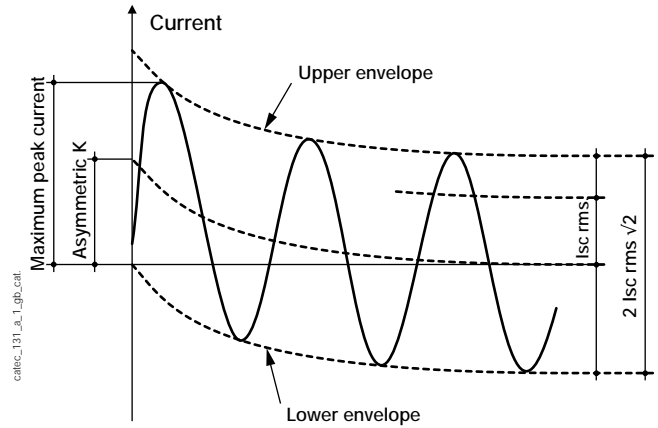

Calculating a source's I_{sc}

► **With one transformer**

- Simplified calculation according to transformer power

Mains supply	I_n	I_{sc} rms
127 / 220V	S (kVA) x 2.5	$I_n \times 20$
220 / 380V	S (kVA) x 1.5	$I_n \times 20$

- Simplified calculation according to transformer short-circuit voltage (u):

$$I_{sc} \text{ (A rms)} = \frac{S}{U\sqrt{3}} \times \frac{100}{u} \times k$$

- S: power (VA)
- U: phase to phase voltage (V)
- u: short circuit voltage (%)
- k: coefficient allowing for upstream impedance (for example, 0.8).

► **With "n" transformers in parallel**

"n" being the number of transformers

- T1; T2; T3 identical
- Short circuit in A, B or C device 1, 2 or 3 must withstand $I_{scA} = (n-1) \times I_{sc}$ of a transformer.
- Short circuit in D, device 4 must withstand: $I_{scB} = n \times I_{sc}$ of a transformer.

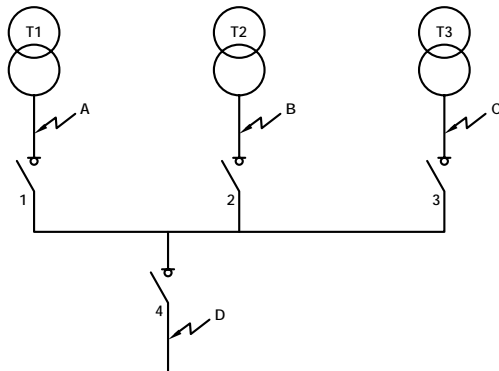

catrec_132_A_1_X_cat

Fig. 1: short circuit with several transformers in parallel

► **Batteries I_{sc}**

I_{sc} values downstream of an accumulator bank are approximately:

- $I_{sc} = 15 \times Q$ (open lead acid)
- $I_{sc} = 40 \times Q$ (air-tight lead acid)
- $I_{sc} = 20 \times Q$ (Ni-Cd)

Q (Ah): capacity in Amps - hour

► **Generator sets I_{sc}**

An alternator's internal impedance depends on its manufacture. This can be characterised as values expressed in%:

- X'd transient reactance:
 - 15 to 20% for a turbo-generator
 - 25 to 35% for salient polar alternator (subtransient reactance is negligible).
- X'o homopolar reactance: this can be estimated at 6% in the absence of more precise indications.

The following may be calculated:

$$I_{sc3} = \frac{k_3 \times P}{U_0 \times X'd}$$

- P: alternator power in kVA
- U_0 : phase to neutral voltage
- X'd: transient reactance

$$I_{sc2} = 0.86 \times I_{sc3}$$

- $k_3 = 0.37$ for I_{sc3} max
- $k_3 = 0.33$ for I_{sc3} min

$$I_{sc1} = \frac{k_1 \times P}{U_0 (2X'd + X'o)}$$

- X'o: homopolar reactance
- $k_1 = 1.1$ per I_{sc1} max
- $k_1 = 1.1$ per I_{sc1} min

Example: P = 400 kVA X'd = 30% X'o = 6% $U_0 = 230$ V

$$I_{sc3} \text{ max} = \frac{0.37 \times 400}{230 \times \frac{30}{100}} = 2.14 \text{ kA} \quad I_{sc1} \text{ max} = \frac{1.1 \times 400}{230 \times \left[2 \times \frac{30}{100} + \frac{6}{100} \right]} = 2.944 \text{ kA}$$

$$I_{sc2} \text{ max} = 1.844 \text{ kA}$$

Weak short circuit currents generated by generator sets make it difficult to protect circuits by usual means. SOCOMEC offers the DIRIS system as a suitable solution.

Calculating a LV installation's I_{sc}

General points

Calculating short-circuit currents enables the following to be defined:

- the protection device's breaking capacity
- the cross-section of conductors enabling:
 - to withstand short circuit temperature stress,
 - to guarantee protection device opening against indirect contact within the time stipulated by IEC 364 standard.
- the mechanical withstand of conductor supports (electrodynamic stress).

The protection device's breaking capacity is established from the I_{sc} calculated at its terminals.

The conductor section depends on the minimum I_{sc} calculated at receptor terminals.

The conductor support mechanical withstand is established by calculating I_{sc} peak deducted from maximum I_{sc} .

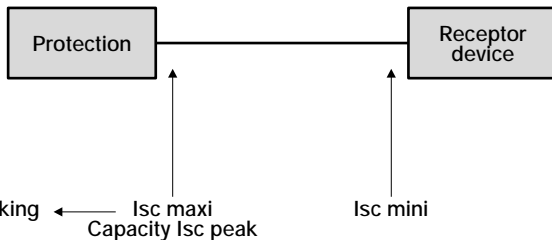

Calculating short-circuit current can be performed by one of the three following methods:

- **Conventional method**
This enables minimum I_{sc} to be calculated. See below.
- **Impedance method**
This method consists of calculating the default loop's impedance Z , taking the power source into account (mains, battery bank, generator sets, etc.). This is an accurate method which enables minimum and maximum I_{sc} to be calculated, but also requires that circuit fault parameters should be known (see page D.23).
- **Quick method**
This method is used when circuit fault parameters are known. Short-circuit current I_{sc} is defined on one point of the network where upstream I_{sc} as well as length and connecting section to upstream point is known (see page D.24). This method only gives the maximum I_{sc} value.

Conventional method

This method gives the minimum I_{sc} value at the end of the installation not supplied by an alternator:

$$I_{sc} = A \times \frac{0.8 U \times S}{2 \rho L}$$

- U : voltage between phases in V
 L : wiring system length in m
 S : conductor section in mm²
 $\rho = 0,028 \text{ m}\Omega \cdot \text{m}$ for copper with fuse protection
 $0,044 \text{ m}\Omega \cdot \text{m}$ for aluminium with fuse protection
 $0,023 \text{ m}\Omega \cdot \text{m}$ for copper with protection by circuit breaker
 $0,037 \text{ m}\Omega \cdot \text{m}$ for aluminium with protection by circuit breaker
 $A = 1$ for circuits with neutral (neutral section = phase section)
 $1,73$ for circuits without neutral
 $0,67$ for circuits with neutral (neutral section = $\frac{1}{2}$ phase section)

For cable sections of 150 mm² and over, account must be taken of the reactance by dividing the I_{sc} value by:

- 150 mm² cable: 1.15
- 185 mm² cable: 1.2
- 240 mm² cable: 1.25
- 300 mm² cable: 1.3

Impedance method

This method consists of adding all the circuit's resistance R and reactance X upstream of the short-circuit (see next page) and then calculating impedance Z .

$$Z_{(m\Omega)} = \sqrt{R_{(m\Omega)}^2 + X_{(m\Omega)}^2}$$

This method enables the following to be calculated:

- I_{sc3} : three phase short-circuit current

$$I_{sc3} = 1.1 \times \frac{U_0}{Z_3}$$

U_0 : phase to neutral voltage (230 V on a 230/400 network)

Z_3 : three phase loop impedance (see page D.23)

- I_{sc2} : short-circuit current between two phases

$$I_{sc2} = 0.86 \times I_{sc3}$$

- I_{sc1} : single phase short-circuit current

$$I_{sc1} = 1.1 \times \frac{U_0}{Z_1}$$

U_0 : phase to neutral voltage (230 V on a 230/400 network)

Z_1 : single phase loop impedance (see page D.23)

- I_{sc} peak
 I_{sc} peak must be calculated when it is necessary to know electrodynamic stress (on busbar supports for example):

$$I_{sc \text{ cresta (kA)}} = I_{sc \text{ rms (kA)}} \times \sqrt{2} \times k$$

k : asymmetric coefficient given below.

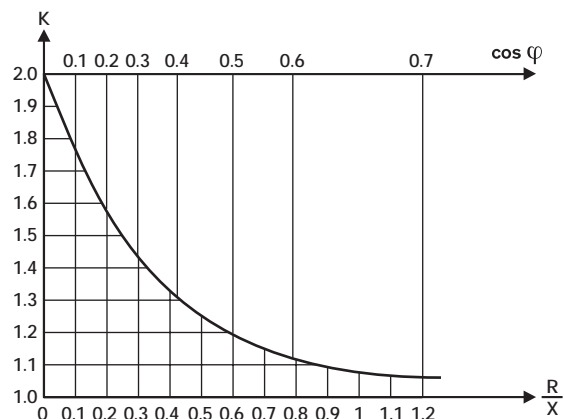

Fig. 1

Note: Value R/X is more often used, as this is more exploitable in this diagram.

$k = 1$ for symmetric short circuit current ($\cos \varphi = 1$).

Short circuit currents

Calculating a LV installation's I_{SC}

Impedance method (continued)

Defining "R" and "X" (network) values

R = Resistance

X = Reactance

The table below gives R and X values for different parts of the circuit up to the short-circuit point.

To calculate the default loop impedance, R and X values must be added separately (see example on page D.23).

Diagram	R and X values																																																			
	<p>Network upstream</p> <p>"R" and "X" values upstream of HV/LV transformers (400 V) according to network short-circuit power (P_{sc} in MVA).</p> <table border="1"> <thead> <tr> <th>MVA</th> <th>NETWORK</th> <th>R (mΩ)</th> <th>X (mΩ)</th> </tr> </thead> <tbody> <tr> <td>500</td> <td>> 63 kV</td> <td>0.04</td> <td>0.35</td> </tr> <tr> <td>250</td> <td>> 24 kV close to power plants</td> <td>0.07</td> <td>0.7</td> </tr> <tr> <td>125</td> <td>> 24 kV far from power plants</td> <td>0.14</td> <td>1.4</td> </tr> </tbody> </table> <p>If short-circuit power (P_{sc} is known) Off-load voltage U_0 (400 V AC or 230 V AC 50 Hz)</p> <div style="display: flex; justify-content: space-around;"> <div style="border: 1px solid black; padding: 5px;"> $R_{(m\Omega)} = 0.1 \times X_{(m\Omega)}$ </div> <div style="border: 1px solid black; padding: 5px;"> $X_{(m\Omega)} = \frac{3.3 \times U_0^2}{P_{CC} \text{ kVA}}$ </div> </div>	MVA	NETWORK	R (mΩ)	X (mΩ)	500	> 63 kV	0.04	0.35	250	> 24 kV close to power plants	0.07	0.7	125	> 24 kV far from power plants	0.14	1.4																																			
	MVA	NETWORK	R (mΩ)	X (mΩ)																																																
	500	> 63 kV	0.04	0.35																																																
250	> 24 kV close to power plants	0.07	0.7																																																	
125	> 24 kV far from power plants	0.14	1.4																																																	
<p>Oil-immersed transformers with secondaries 400 V</p> <p>Values of "R" and "X" according to the power of the transformer.</p> <table border="1"> <thead> <tr> <th>P (kVA)</th> <th>50</th> <th>100</th> <th>160</th> <th>200</th> <th>250</th> <th>400</th> <th>630</th> <th>1000</th> <th>1250</th> <th>1600</th> <th>2000</th> <th>2500</th> </tr> </thead> <tbody> <tr> <td>I_{sc3} (kA)</td> <td>1.80</td> <td>3.60</td> <td>5.76</td> <td>7.20</td> <td>9.00</td> <td>14.43</td> <td>22.68</td> <td>24.01</td> <td>30.03</td> <td>38.44</td> <td>48.04</td> <td>60.07</td> </tr> <tr> <td>R (mΩ)</td> <td>43.7</td> <td>21.9</td> <td>13.7</td> <td>10.9</td> <td>8.7</td> <td>5.5</td> <td>3.5</td> <td>3.3</td> <td>2.6</td> <td>2.0</td> <td>1.6</td> <td>1.31</td> </tr> <tr> <td>X (mΩ)</td> <td>134</td> <td>67</td> <td>41.9</td> <td>33.5</td> <td>26.8</td> <td>16.8</td> <td>10.6</td> <td>10.0</td> <td>8.0</td> <td>6.3</td> <td>5.0</td> <td>4.01</td> </tr> </tbody> </table>	P (kVA)	50	100	160	200	250	400	630	1000	1250	1600	2000	2500	I_{sc3} (kA)	1.80	3.60	5.76	7.20	9.00	14.43	22.68	24.01	30.03	38.44	48.04	60.07	R (mΩ)	43.7	21.9	13.7	10.9	8.7	5.5	3.5	3.3	2.6	2.0	1.6	1.31	X (mΩ)	134	67	41.9	33.5	26.8	16.8	10.6	10.0	8.0	6.3	5.0	4.01
P (kVA)	50	100	160	200	250	400	630	1000	1250	1600	2000	2500																																								
I_{sc3} (kA)	1.80	3.60	5.76	7.20	9.00	14.43	22.68	24.01	30.03	38.44	48.04	60.07																																								
R (mΩ)	43.7	21.9	13.7	10.9	8.7	5.5	3.5	3.3	2.6	2.0	1.6	1.31																																								
X (mΩ)	134	67	41.9	33.5	26.8	16.8	10.6	10.0	8.0	6.3	5.0	4.01																																								
<p>Conductors</p> <div style="border: 1px solid black; padding: 5px; margin-bottom: 5px;"> $R_{(m\Omega)} = \frac{\rho \times l_{(m)}}{S_{(mm^2)}} \quad \text{with} \quad \rho = \frac{m\Omega \times mm^2}{m}$ </div> <table border="1"> <thead> <tr> <th rowspan="2"></th> <th colspan="2">RESISTIVITY ρ [10^{-6} mΩ.m]</th> </tr> <tr> <th>max. I_{sc}</th> <th>min. I_{sc}</th> </tr> </thead> <tbody> <tr> <td></td> <td></td> <td>Fuse protection</td> <td>Protection by circuit breaker</td> </tr> <tr> <td>Copper</td> <td>18.51</td> <td>28</td> <td>23</td> </tr> <tr> <td>Aluminium</td> <td>29.4</td> <td>44</td> <td>37</td> </tr> </tbody> </table> <div style="border: 1px solid black; padding: 5px; margin-bottom: 5px;"> $X_{(m\Omega)} = 0.08 \times I_{(m)} \text{ (three-pole cables)}^{(1)}$ $X_{(m\Omega)} = 0.13 \times I_{(m)} \text{ (single-pole cables)}^{(1)}$ $X_{(m\Omega)} = 0.09 \times I_{(m)} \text{ (separate single-conductor cables)}^{(1)}$ </div> <div style="border: 1px solid black; padding: 5px;"> $X_{(m\Omega)} = 0.15 \times I_{(m)} \text{ (busbars)}^{(1)}$ </div> <p>(1) Copper and aluminium</p>		RESISTIVITY ρ [10^{-6} mΩ.m]		max. I_{sc}	min. I_{sc}			Fuse protection	Protection by circuit breaker	Copper	18.51	28	23	Aluminium	29.4	44	37																																			
		RESISTIVITY ρ [10^{-6} mΩ.m]																																																		
	max. I_{sc}	min. I_{sc}																																																		
		Fuse protection	Protection by circuit breaker																																																	
Copper	18.51	28	23																																																	
Aluminium	29.4	44	37																																																	
<p>Device in closed position</p> <div style="border: 1px solid black; padding: 5px; text-align: center;"> $R = 0 \text{ and } X = 0.15 \text{ m}\Omega$ </div>																																																				

Calculating a LV installation's I_{SC} (continued)

Impedance method (continued)

Calculating I_{sc} (impedance method) (continued)

ρ copper = 18.51
 ρ aluminium = 29.4
 $U_0 = 230$ V

	PHASES		NEUTRAL		PROTECTION	
	R	X	R	X	R	X
Network: 250 MVA	$R = 0.07$ m Ω	$X = 0.7$ m Ω	0.07	0.7		
Transformer da 630 kVA	$R = 3.5$ m Ω	$X = 10.6$ m Ω	3.5	10.6		
Cables: Aluminium						
Ph: $l = 10$ m 4×240 mm	$R = \frac{29.4 \times 10}{240 \times 4} = 0.306$ m Ω	$X = \frac{0.13 \times 10}{4} = 0.325$ m Ω	0.306	0.325		
N: $l = 10$ m 2×240 mm	$R = \frac{29.4 \times 10}{240 \times 2} = 0.612$ m Ω	$X = \frac{0.13 \times 10}{2} = 0.65$ m Ω		0.612	0.65	
PE: $l = 12$ m 1×240 mm	$R = \frac{29.4 \times 12}{240} = 1.47$ m Ω	$X = 0.13 \times 12 = 1.56$ m Ω			1.47	1.56
Device	(transformer protection)	$X = 0.15$ m Ω		0.15		
	Sub-total: TGBT level "input"		3.87	11.77	0.612	0.65
Busbars copper $l = 3$ m						
Ph: $2 \times 100 \times 5$	$R = \frac{18.51 \times 3}{2 \times 100 \times 5} = 0.055$ m Ω	$X = 0.15 \times 3 = 0.45$ m Ω	0.055	0.45		
N: $1 \times 100 \times 5$	$R = \frac{18.51 \times 3}{1 \times 100 \times 5} = 0.11$ m Ω	$X = 0.15 \times 3 = 0.45$ m Ω		0.11	0.45	
PE: $1 \times 40 \times 5$	$R = \frac{18.51 \times 3}{40 \times 5} = 0.277$ m Ω	$X = 0.15 \times 3 = 0.45$ m Ω			0.277	0.45
Total at busbars level:	3.925		12.22	0.722	1.1	1.75

At TGBT input

- Three phase loop impedance:

$$Z_3 = \sqrt{R_{ph}^2 + X_{ph}^2} = \sqrt{(3.87)^2 + (11.77)^2} = 12.39 \text{ m}\Omega$$

$$I_{sc3 \text{ max.}} = \frac{1.1 \times 230 \text{ V}}{12.39 \text{ m}\Omega} = 20.5 \text{ kA}$$

$$I_{sc2 \text{ max.}} = 0.86 \times 20.5 \text{ kA} = 17.6 \text{ kA}$$

- Single-phase loop impedance:

$$Z_1 = \sqrt{(R_{ph} + R_n)^2 + (X_{ph} + X_n)^2}$$

$$Z_1 = \sqrt{(3.87 + 0.612)^2 + (11.77 + 0.65)^2} = 13.2 \text{ m}\Omega$$

$$I_{c1} = \frac{1.1 \times 230 \text{ V}}{13.2 \text{ m}\Omega} = 19.2 \text{ kA}$$

At busbar input

- Three phase loop impedance:

$$Z_3 = \sqrt{R_{ph}^2 + X_{ph}^2} = \sqrt{(3.925)^2 + (12.22)^2} = 12.8 \text{ m}\Omega$$

$$I'_{sc3 \text{ maxi}} = \frac{1.1 \times 230 \text{ V}}{12.8 \text{ m}\Omega} = 19.8 \text{ kA}$$

$$I'_{sc2 \text{ maxi}} = 0.86 \times 19.8 \text{ kA} = 17 \text{ kA}$$

$$\frac{R}{X} = \frac{3.925}{12.22} = 0.32 \text{ according to fig. 1 page D.21, } k = 1.4$$

$$I'_{sc3 \text{ peak}} = 19.8 \times \sqrt{2} \times 1.4 = 39.2 \text{ kA}$$

This 39.7 kA peak value is necessary to define the dynamic withstand of the bars and of the piece of equipment.

- Impedenza del circuito monofase:

$$Z_1 = \sqrt{(R_{ph} + R_n)^2 + (X_{ph} + X_n)^2} = \sqrt{(3.925 + 0.722)^2 + (12.22 + 1.1)^2} = 14.1 \text{ m}\Omega$$

$$I'_{sc1} = \frac{1.1 \times 230 \text{ V}}{14.1 \text{ m}\Omega} = 18 \text{ kA}$$

- Phase/protection single-phase loop impedance:

$$Z_1 = \sqrt{(4.11 + 2.62)^2 + (12.22 + 1.1)^2} = 14.92 \text{ m}\Omega$$

$$I_{sc1 \text{ mini}} = \frac{230 \text{ V}}{14.3 \text{ m}\Omega} = 16 \text{ kA} \quad I_{sc1 \text{ mini}} = \frac{230 \text{ V}}{14.92 \text{ m}\Omega} = 15.4 \text{ kA}$$

Calculating minimum I_{sc} example

Calculating minimum I_{sc} is identical to the previous calculation, replacing copper and aluminium resistivities by:

$\rho_{\text{copper}} = 28$ $\rho_{\text{alu}} = 44$

- Phase/neutral single-phase loop impedance:

$$Z_1 = \sqrt{(4.11 + 1.085)^2 + (12.22 + 1.1)^2} = 14.3 \text{ m}\Omega$$

Protection of wiring systems

Short-circuit currents lead to temperature stress in conductors. To avoid damaging or eroding cable insulation (which may in turn lead to insulation faults) or busbar supports, conductors having the following indicated minimal sections must be used.

► Busbars

Short-circuit thermal effects on busbars are caused by conductor temperature rise. This temperature rise must be compatible with busbar support characteristics.

Example: for a SOCOMEC busbar support (with a busbar temperature of 80 °C prior to short-circuit).

$$S_{\text{min.}} (\text{mm}^2) = 1000 \times \frac{I_{\text{sc}} (\text{kA})}{70} \times \sqrt{t} (\text{s})$$

S min.: minimum phase cross-section

I_{sc}: rms short-circuit current

t: protective device breaking time

Also see the busbar calculation on page D.73.

► Insulated conductors

The minimum cross-section is established as follows:

$$S_{\text{mini}} (\text{mm}^2) = 1000 \times \frac{I_{\text{sc}} (\text{kA})}{k} \times \sqrt{t} (\text{s})$$

I_{sc}: minimum short-circuit current in kA rms (see page D.20).

t: protective device tripping time in secs.

k: constant, depending on the insulation (see table B).

► Insulated conductors (continued)

Table B: constant k (IEC 60364)

	INSULATION	CONDUCTORS	
		COPPER	ALUMINIUM
Live conductors or protective conductors which are part	Rubber	115	76
	Butyl	143	94
Protective conductors which are part of the wiring system	Rubber	143	95
	Butyl	176	116
	uninsulated ¹⁾	159 ¹⁾ 138 ²⁾	105 ¹⁾ 91 ²⁾

1) Premises without fire risk

2) Premises with fire risk

To avoid doing the calculation, please refer to table A which gives the coefficient by which the short circuit current must be multiplied to obtain the minimum cross-section.

$$\text{Section mini. (mm}^2\text{)} = k_{\text{sc}} \times I_{\text{sc mini.}} (\text{kA})$$

Example

For a copper cable, insulated with PVC and protected by DIRIS CP adjusted to *t_s* = 100 ms, *I_{sc min.}* = 22 kA. This gives: *k_{sc}* = 2.75 for live conductors *S min.* = 2.75 x 22 = 60 mm² A 70 mm² section will be chosen

The same conductor in aluminium should have a minimum cross-section of 60 mm² x 1.5 = 90 mm²

► Maximum conductor length

Having already established minimum conductor length, ensure that the protective device placed upstream of conductors has a tripping time compatible with the conductors' maximum temperature stress. To do this, the minimum short circuit current must be sufficient to trip the protection device. Conductor length must be within the limits given by tables A and B page D.26.

Table A: *K_{sc}* coefficient

CUT-OFF TIME IN <i>m/s</i>	For a 1 kA rms short circuit current						
	LIVE COPPER CONDUCTOR MINIMUM CROSS SECTION		COPPER PROTECTION CONDUCTOR MINIMUM CROSS SECTION				
	INSULATION ► PVC	PR-EPR	CONDUCTORS FORMING PART OF WIRING SYSTEM		CONDUCTORS FORMING PART OF WIRING SYSTEM		
			PVC	PR	PVC	PR	UNINSULATED
5	0.62	0.50	0.62	0.50	0.50	0.40	0.45
10	0.87	0.70	0.87	0.70	0.70	0.57	0.63
15	1.06	0.86	1.06	0.86	0.86	0.70	0.77
25	1.37	1.10	1.37	1.10	1.10	0.89	0.99
35	1.63	1.31	1.63	1.31	1.31	1.06	1.18
50	1.94	1.58	1.94	1.56	1.56	1.27	1.40
60	2.13	1.72	2.13	1.72	1.72	1.40	1.54
75	2.38	1.89	2.38	1.89	1.89	1.54	1.72
100	2.75	2.21	2.75	2.21	2.21	1.79	1.99
125	3.07	2.47	3.07	2.47	2.47	2.00	2.22
150	3.37	2.71	3.37	2.71	2.71	2.20	2.44
175	3.64	2.93	3.64	2.93	2.93	2.38	2.63
200	3.89	3.13	3.89	3.13	3.13	2.54	2.81
250	4.35	3.50	4.35	3.50	3.50	2.84	3.15
300	4.76	3.83	4.76	3.83	3.83	3.11	3.44
400	5.50	4.42	5.50	4.42	4.42	3.59	3.98
500	6.15	4.95	6.15	4.95	4.95	4.02	4.45
1000	8.70	6.99	8.70	6.99	6.99	5.68	6.29

For aluminium conductors, multiply the values in the table by 1.5.

Short circuit currents

Fuse protection of wiring systems

► Maximum length of conductors protected by fuses

Table A and B indicate maximum lengths in the following conditions:

- 230/400 V three-phase circuit,
- minimal short-circuit current,
- contact line neutral section = phases section,
- copper conductors.

These tables are valid whatever the cable insulation (PVC, PR, EPR). When two values are given, the first corresponds to PVC cables and the second to PR/EPR cables.

The lengths must be multiplied by the coefficients in table C for 230 V/400 V three-phase networks with distributed neutral, or 230 single-phase networks.

For aluminium cable: multiply the lengths in the tables by 0.41.

Table A: maximum cable lengths in m protected by gG fuses

HP C S (mm ²)	16	20	25	32	40	50	63	80	100	125	160	200	250	315	400	500	630	800	1000	1250	
1.5	82	59/61	38/47	18/22	13/16	6/7															
2.5		102	82	49/56	35/43	16/20	12/15	5/7													
4			131	89	76	42/52	31/39	14/17	8/10	4/5											
6				134	113	78	67/74	31/39	18/23	10/12	7/9										
10					189	129	112	74	51/57	27/34	19/24	9/12	7/9	3/4							
16							179	119	91	67	49/56	24/30	18/23	9/11	5/7	3/4					
25								186	143	104	88	59/61	45/53	22/27	13/16	7/9	4/5				
35									200	146	123	86	75	43/52	25/36	14/18	8/11	4/5			
50										198	167	117	101	71	45/74	26/33	16/22	8/11	5/7		
70											246	172	150	104	80	57/60	34/42	17/22	11/14		
95												233	203	141	109	82	62	32/40	20/25	9/11	
120													256	179	137	103	80	51/57	32/40	14/18	
150														272	190	145	110	85	61	42/48	20/24
185															220	169	127	98	70	56	27/34
240																205	155	119	85	68	43/46

Table B: maximum cable lengths in m protected by aM fuses

HP C S (mm ²)	16	20	25	32	40	50	63	80	100	125	160	200	250	315	400	500	630	800	1000	1250	
1.5	28/33	19/23	13/15	8/10	6/7																
2.5	67	47/54	32/38	20/24	14/16	9/11	6/7														
4	108	86	69	47/54	32/38	22/25	14/17	9/11	6/7												
6	161	129	104	81	65/66	45/52	29/34	19/23	13/15	9/10	6/7										
10				135	108	88	68	47/54	32/38	21/25	14/16	9/11	6/7								
16						140	109	86	69	49/55	32/38	21/25	14/17	9/11							
25																					
35																					
50																					
70																					
95																					
120																					
150																					
185																					
240																					

Table C: corrective coefficients for other networks

USE	COEFFICIENTE
Neutral section = 0.5 x phase section	0.67 ⁽¹⁾
Circuit without neutral	1.73

(1) Entry to the table is through the phase section.

Direct and indirect contacts

Protection against indirect contacts

Definition

Direct contact is the contact of persons with active parts (phases, neutral) which are normally live (busbars, terminals, etc.), which result in an electric shock.

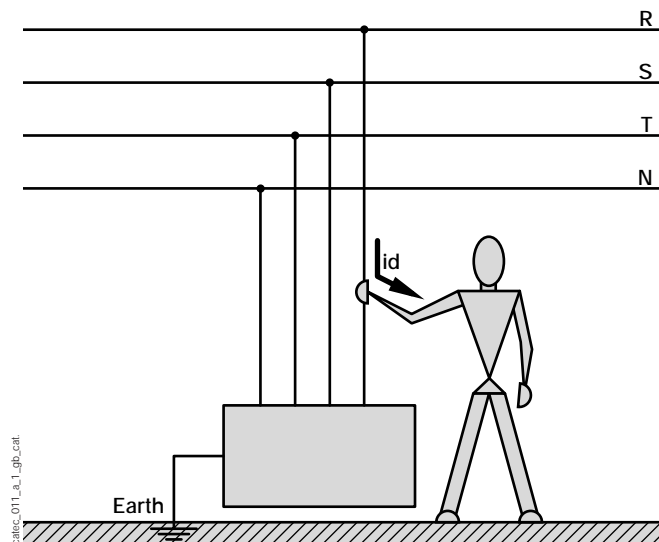

Fig. 1: direct contact

Protective measures

Protecting against direct contact is ensured by one of the following measures:

- placing live conductors out of reach by using obstacles or placing at a distance.
- insulating live conductors.
- using barriers or enclosures: the minimum degree of protection offered by the enclosure must be IP 2x or xxB for live parts. Enclosure opening shall only be possible in one of the following instances:
 - with a key or other tool
 - after switching off active parts
 - if a second barrier with IP > 2x or xxB is employed inside the enclosure (see IP definition on page D.11).
- using 30 mA residual differential-current devices. This is an accepted complementary protective measure, should the other protective measures fail.
- using ELV (Extra-Low Voltage).

Using ELV

Use of ELV (for a definition of this see page D.6) represents protection against both direct and indirect contact.

The following can be distinguished:

• SELV

Security Extra-Low Voltage. This must be:

- produced by certain sources such as security transformers, inverters, battery banks, and generator sets, etc.
- completely independent from elements liable to undergo differential potential (another installation's earth, or another circuit, etc.).

• PELV

Protection Extra-Low Voltage. This is identical to SELV, except that it has earth connection for operating reasons (electronics, computing, etc.). Using PELV may cause certain restrictions as compared to SELV concerning protection against direct contact.

• FELV

Functional Extra-Low Voltage. This covers all other ELV applications. It does not offer protection against direct or indirect contact.

Complementary protection against the direct contacts

Whatever the neutral load, complementary protection against direct contacts is provided, in particular by the use of high sensitivity RCD (≤ 30 mA).

Standards IEC 60364 and IEC 60364 require the use of such devices in the following cases in particular:

- circuits supplying socket outlets ≤ 32 A,
- temporary installations, fairground installations,
- worksite installations,
- bathrooms, swimming pools,
- caravans, pleasure boats,
- vehicle power supply,
- agricultural and horticultural establishments,
- heating cables and coverings embedded in the floor or walls of a building.

These complementary protective measures against direct contacts, according to standard IEC 60479, are no longer acceptable when the contact voltage risks reaching 500 V: human impedance risks allowing a dangerous current higher than 500 mA to pass through the body.

Direct and indirect contacts

Protection against indirect contacts

Definition

Indirect contact is the contact of persons with conductive parts which have been accidentally made live following an insulation fault. Protection against indirect contact can be performed:

- either without automatic disconnection of supply
- or with automatic disconnection of supply.

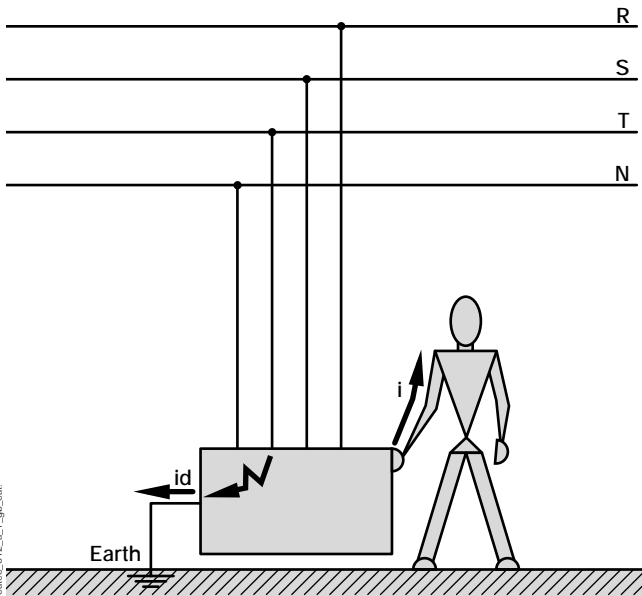

Fig. 1: indirect contact

Protection without automatic disconnection of supply

Protection against indirect contacts without automatic disconnection of supply can be ensured by:

- using ELV (Extra-Low Voltage) (see page D.27),
- separating masses so that none can be simultaneously in contact with both masses,
- double or reinforced insulation of material (class II),
- non earth linked equipotential connection of all simultaneously accessible masses,
- electric separation (by transformer for circuits < 500 V).

Protection with automatic disconnection of supply

Protection against indirect contact with automatic disconnection of supply consists of separating from the supply circuits or material, with an insulation fault between an active part and the mass.

To prevent hazardous physiological effects for personnel who would be in contact with the faulty part, contact voltage U_c is limited to a limit value U_L .

The latter is determined according to:

- admissible current I_L for the human body,
- current flow time (see fig. 1 page D.30),
- earth-link arrangement,
- installation specifications.

PRESUMED CONTACT VOLTAGE (V)	PROTECTION DEVICE MAXIMUM BREAKING TIME (S)
	$U_L = 50$ V
25	5
50	5
75	0.60
90	0.45
110	-
120	0.34
150	0.27
220	0.17
230	-
280	0.12
350	0.08
500	0.04

This installation switch-off is performed differently according to linking arrangements (neutral loads).

IEC 364 standard stipulates the protection device's maximum cut-off time in normal ($U_L = 50$ V) and in damp conditions ($U_L = 25$ V), (U_L is the highest contact voltage that people can withstand without danger), (see table above).

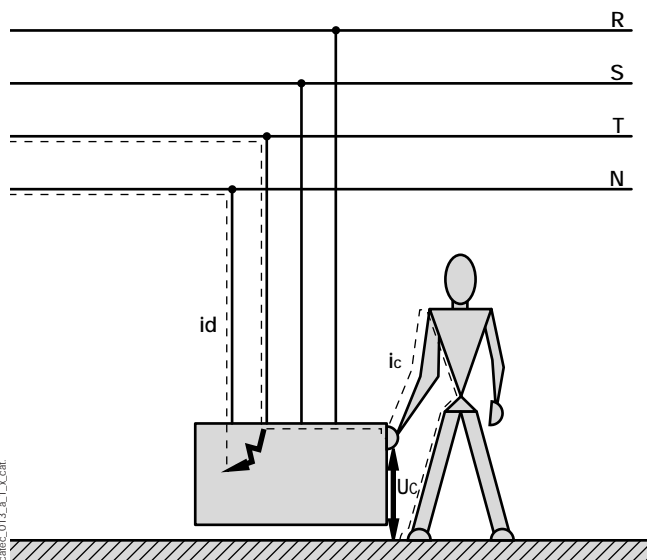

Fig. 2: contact voltage limit value U_L

Protection against indirect contacts (continued)

► Protection with automatic disconnection of supply (continued)

• TT load

With TT load protection is ensured by differential devices. In this case, the conductor cross-section and length are not taken into consideration.

Ensure that earth connection is as follows:

$$R_T < \frac{U_L}{I_{\Delta n}}$$

U_L : limit voltage
 $I_{\Delta n}$: differential device adjustment current

Example: should there be a fault, contact voltage can be limited to $U_L = 50$ V.

The differential device is adjusted to $I_{\Delta n} = 500$ mA = 0.5 A.

Earth connection resistance must not exceed:

$$R_{T \text{ maxi}} = \frac{50 \text{ V}}{0.5 \text{ A}} = 100 \Omega$$

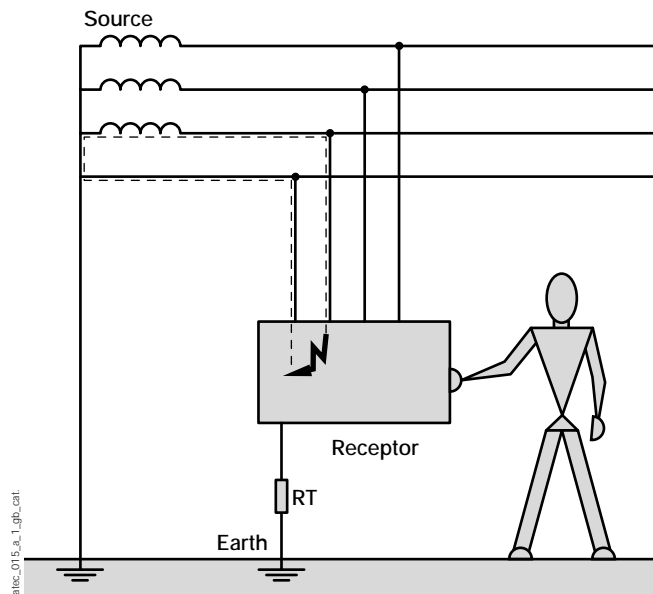

Fig. 1: TT load fault current

• TN and IT load

Introduction

When the network is not protected by a differential device, correct co-ordination between the protection device and the choice of conductors must be ensured.

Indeed, if the conductor impedance is too high, there is a risk of a limited fault current tripping the protection device over a longer period of time than is stipulated by IEC 364 standard.

The resulting current may thus cause a dangerous contact voltage. To limit loop impedance, conductor length for a given section should be limited.

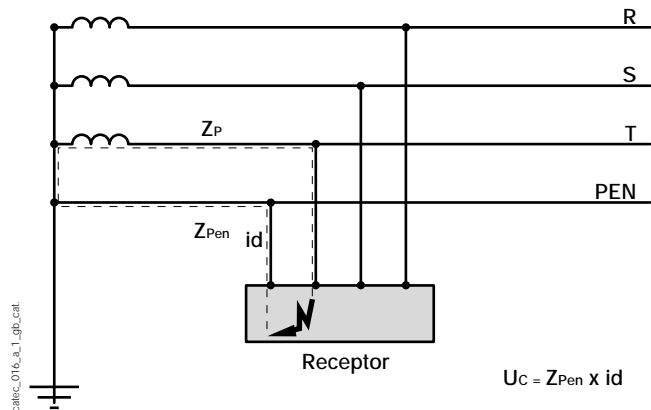

Fig. 2: TN load current fault

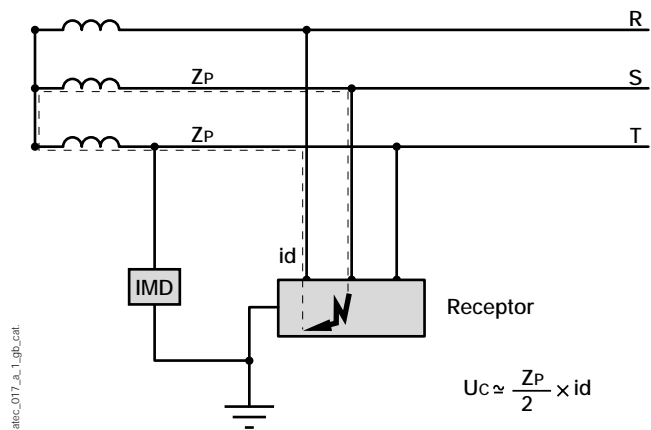

Fig. 3: IT load current fault

Note: protection against overcurrents is only effective in the presence of dead faults.

A RESYS differential device or a DLRD 470 used as a pre-alarm, are effective means of preventing impedance faults and the maintaining of dangerous voltages.

Direct and indirect contacts

Protection against indirect contacts (continued)

► Protection with automatic disconnection of supply (continued)

- TN and IT load (continued)

Maximum breaking time

To avoid being in zones 3 and 4 in figure below, IEC 364 specifies a maximum breaking time according to the electrical network and voltage limit:

- 50 V for dry premises
- 25 V for damp premises, building sites and livestock buildings, etc.

Table A: protection device's maximum breaking time in seconds

NOMINAL VOLTAGE ▼	LOAD ▶	TN	IT WITHOUT NEUTRAL	IT WITH NEUTRAL
	U_L ▶	50	50	50
230/400		0.4	0.4	0.8
400/690		0.2	0.2	0.4

Special case

With a TN load, breaking time can be greater than the time given by table A (but still less than 5 sec.) if:

- the circuit is not a terminal circuit and does not supply a mobile or portable load
- the circuit does not supply equipment or current outlet
- one of the following 2 conditions is met:
 - the principal equipotential link is doubled by an equipotential link identical to the principal link
 - the protection conductor's resistance R_{pe} is:

$$R_{pe} < \frac{50}{U_o} \times (R_{pe} + Z_a)$$

U_o : network phase to neutral voltage

Z_a : impedance including the source and the live conductor up to fault point.

Maximum conductor length

The conductor's limit length can be determined by an approximate calculation, valid for installations supplied by a star-delta or zigzag coupling transformer.

$$L (m) = K \frac{U_o \times S}{(1 + m) I_d}$$

U_o : phase-to-neutral voltage (230 V on a 230/400 network)

S : phase conductors cross section in mm^2 with TN and IT loads without neutral

$m = S/S_{pe}$ S_{pe} : PE or PEN section

I_d : fault current in A

Fuse protection: current reached for melting time equal to protection device's opening time (maximum lengths are given in table B on page D.26)

K : variable according to the neutral load and the conductor (see table B).

Table B: K values

ARRANGEMENT ▶ CONDUCTOR ▼	TN	IT
	WITHOUT NEUTRAL	WITH NEUTRAL
Copper	34.7	17.3
Aluminium	21.6	11

The influence of reactance is negligible for cross-sections less than 120 mm^2 . Beyond that resistance has to be increased by:

- 15% for 150 mm^2 cross section
- 20% for 185 mm^2 cross section
- 25% for 240 mm^2 cross section
- 30% for 300 mm^2 cross section

For cross sections greater than above: an exact impedance calculation must be performed using $X = 0.08 m\Omega / m$.

► Effect of electrical current on the human body

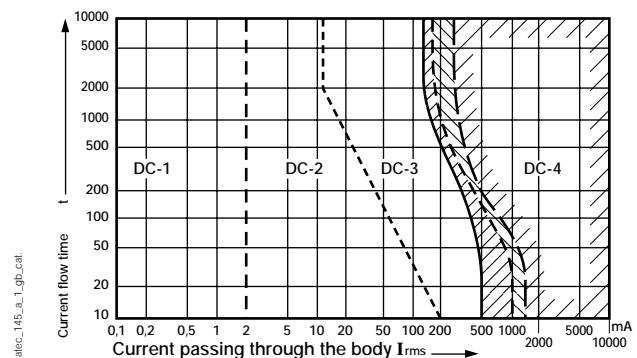
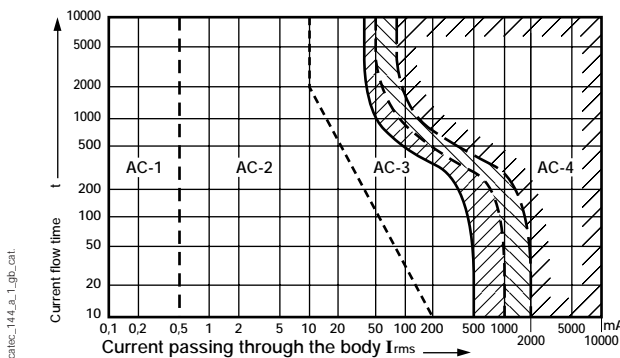

The current passing through the human body, by its physiopathological effect, affects the circulatory and respiratory functions and can lead to death, and for high values, cause serious burns.

Zones -1 to -4 correspond to the different levels of effect:

- AC/DC-1: non-perception
- AC/DC-2: perception
- AC/DC-3: reversible effects, muscle contraction
- AC/DC-4: possibility of irreversible effects.

Fuse protection against indirect contacts

► Maximum length of conductors protected by fuses

The length of conductors protected against indirect contacts must be limited.

Tables B and C give a direct reading of the maximum lengths of copper conductors. They are determined in the following conditions:

- network 230 V/400 V
- TN load
- maximum contact voltage $U_L = 50$ V.

For other uses, the value read in tables B and C must be multiplied by the coefficient in table A.

Table A: correction coefficient

IT load without neutral	0.86
IT load with neutral	0.5
Neutral cross section = 1/2 phase cross section	0.67
Aluminium conductor	0.625

Table B: maximum lengths (in m) of conductors protected by gG fuses

S (mm²) \	16	20	25	32	40	50	63	80	100	125	160	200	250	315	400	500	630	800	1000	1250
1.5	53	40	32	22	18	13	11	7	8	4	3									
2.5	88	66	53	36	31	21	18	12	9	7	6	4								
4	141	106	85	58	49	33	29	19	15	11	9	6	6	4						
6	212	159	127	87	73	50	43	29	22	16	14	10	8	6	4					
10	353	265	212	145	122	84	72	48	37	28	23	16	14	10	7	6	4			
16	566	424	339	231	196	134	116	77	59	43	36	25	22	15	12	9	7	5	4	
25	884	663	530	361	306	209	181	120	92	67	57	40	35	24	18	14	11	8	6	4
35		928	742	506	428	293	253	169	129	94	80	56	48	34	26	20	15	11	9	6
50				687	581	398	343	229	176	128	108	76	66	46	35	27	20	15	12	8
70					856	586	506	337	259	189	159	11	97	67	52	39	30	22	17	11
95						795	687	458	351	256	216	151	131	92	70	53	41	29	23	16
120							868	578	444	323	273	191	166	116	89	67	62	37	23	20
150								615	472	343	290	203	178	123	94	71	54	39	31	21
185								714	547	399	336	235	205	145	110	82	64	46	36	24
240									666	485	409	286	249	173	133	100	77	55	44	29
300										566	477	334	290	202	155	117	90	65	51	34

Table C: maximum lengths (in m) of conductors protected by aM fuses

S (mm²) \	16	20	25	32	40	50	63	80	100	125	160	200	250	315	400	500	630	800	1000	1250
1.5	28	23	18	14	11	9	7	6	5	4										
2.5	47	38	30	24	19	15	12	9	8	6	5									
4	75	60	48	38	30	24	19	15	12	10	8		6	5	4					
6	113	90	72	57	45	36	29	23	18	14	11	9	7	6	5	4				
10	188	151	121	94	75	60	48	38	30	24	19	15	12	10	8	6	5	4		
16	301	241	193	151	121	96	77	60	48	39	30	24	19	15	12	10	8	6	5	4
25	470	377	302	236	188	151	120	94	75	60	47	38	30	24	19	16	12	9	8	6
35	658	527	422	330	264	211	167	132	105	84	66	53	42	33	26	21	17	13	11	8
50	891	714	572	447	357	285	227	179	144	115	90	72	57	46	36	29	23	18	14	11
70			845	660	527	422	335	264	211	169	132	105	84	67	53	42	33	26	21	17
95				895	716	572	454	358	286	229	179	143	115	91	72	57	45	36	29	23
120					904	723	574	462	362	289	226	181	145	115	90	72	57	45	36	29
150						794	630	496	397	317	248	198	159	126	99	79	63	50	40	32
185							744	586	469	375	293	234	188	149	117	94	74	59	47	38
240								730	584	467	365	292	234	185	146	117	93	73	58	47
300									702	562	439	351	281	223	175	140	11	88	70	56

Example

A circuit consists of a copper cable 3 x 6 mm² and is protected by a 40 A gG fuse. Its length must be less than 73 m so that protection against indirect contacts is guaranteed in TN 230 V/400 V.

- if the cable is an aluminium one, maximum length is:
 $0.625 \times 73 \text{ m} = 45.6 \text{ m}$
- in IT load with neutral and an aluminium cable, the length is:
 $0.625 \times 0.6 \times 73 \text{ m} = 22.8 \text{ m}$.

Direct and indirect contacts

Protection against indirect contacts by differential relay

TT load

Differential protection constitutes practically the only means of protection against indirect contacts in this load.

To avoid, for example, a contact voltage higher than 50 V, the current $I_{\Delta n}$ must be such that:

$$I_{\Delta n} \leq \frac{50}{R_p}$$

R_p : earth connection resistance in Ω

Where the earth connection is particularly difficult to make and where the values may exceed a hundred ohms (high mountain, arid areas, etc.), installation of high sensitivity (H.S.) devices is an answer to the previous situation.

TNS load

In this load, the fault current is equivalent to a short circuit current between phase and neutral. The latter is eliminated by the appropriate devices (fuses, circuit breakers, etc.) in a time compatible with the protection against indirect contacts. When this time cannot be respected (wiring systems that are too long, hence insufficient minimum I_{sc} , protection device reaction time too long, etc.), it is necessary to accompany the overcurrent protection with a differential protection device. This arrangement allows protection to be provided against indirect contacts, with practically any length of wiring system.

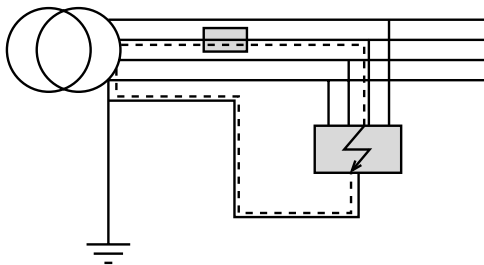

IT load

Circuit breaking is normally not necessary at the first fault. A dangerous contact voltage can occur on the second fault or where masses are connected to non-interconnected or distant earth connections or between simultaneously accessible masses connected to the same earth connection and whose protection circuit impedance is too high.

For these reasons, in IT load, a differential device is obligatory:

- at the origin of the parts of the installation whose protection networks or masses are connected to non-interconnected earth connections,
- in the same situation as that mentioned in TNS (breaking conditions on second fault not provided by the overcurrent protection devices in the required safety conditions).

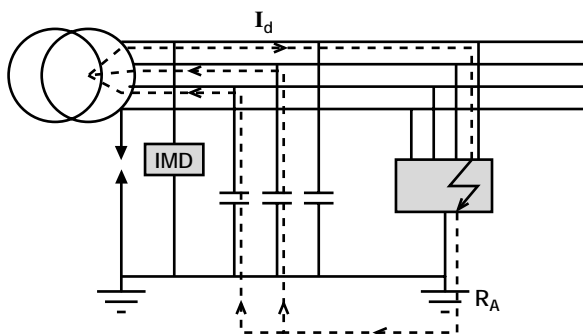

Protection against indirect contacts of the mass groups connected to independent earth connections

In TT neutral load as in IT, when the masses of the electrical equipment are connected to separate earth connections downstream of the same power supply, each group of masses must be protected by its own dedicated device.

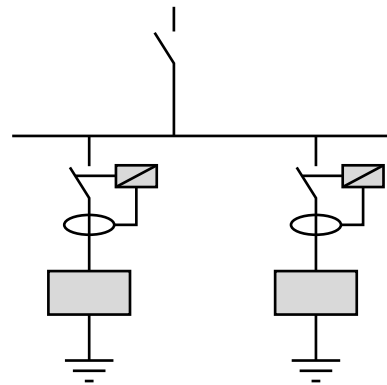

Exemption from high sensitivity (H.S.) protection of computer equipment sockets

Computer equipment can have high leakage currents, making its use downstream of a high sensitivity differential device hazardous.

A proposal was made by the labour ministry with the decree of 08/01/92 fixing the practical arrangements for the taking of complementary protective measures against direct contacts; thus sockets ≤ 32 A supplying fixed or semi-fixed class I equipment of which breaking not caused by an insulation fault is incompatible with service requirements may be exempted from the installation of H.S. devices.

Only the head of the establishment concerned can decide which sockets which may benefit from this exemption. These dedicated sockets, without H.S. protection, must be specifically identified so as to prevent them being used for other applications.

Protection against indirect contacts by differential relay (continued)

Definitions

Voltage drop is the voltage difference observed between the installation's point of origin and the receptor's connection point.

To ensure correct receptor operating, standards IEC 60 364 and IEC 364 define a maximum voltage drop (see table A).

Table A: IEC 60 364 maximum voltage drop

	LIGHTING	OTHER USES
Direct public mains LV supply		
• single phase circuits	6%	10%
• three-phase circuits	3%	5%
HV/LV substation supply		
• single phase circuits	12%	16%
• three-phase circuits	6%	8%

Calculating voltage drop in a cable of length L

$$\Delta u = K_u \times I \text{ (Amperes)} \times L \text{ (km)}$$

Table B: K_u values

CABLE CROSS SECTION mm ²	DC CURRENT	Multiconductor cables or trefoil monoconductor cables			Single-conductor joined cable layout in flat formation			Separate single-conductor cables		
		cos 0.3	cos 0.5	cos 0.8	cos 0.3	cos 0.5	cos 0.8	cos 0.3	cos 0.5	cos 0.8
1.5	30.67	4.68	7.74	12.31	4.69	7.74	12.32	4.72	7.78	12.34
2.5	18.40	2.84	4.67	7.41	85	4.68	7.41	2.88	4.71	7.44
4	11.50	1.80	2.94	4.65	1.81	2.95	4.65	1.85	2.99	4.68
6	7.67	1.23	1.99	3.11	1.24	1.99	3.12	1.27	2.03	3.14
10	4.60	0.77	1.22	1.89	0.78	1.23	1.89	0.81	1.26	1.92
16	2.88	0.51	0.79	1.20	0.52	0.80	1.20	0.55	0.83	1.23
25	1.84	0.35	0.53	0.78	0.36	0.54	0.78	0.40	0.57	0.81
35	1.31	0.27	0.40	0.57	0.28	0.41	0.58	0.32	0.44	0.60
50	0.92	0.21	0.30	0.42	0.22	0.31	0.42	0.26	0.34	0.45
70	0.66	0.17	0.23	0.31	0.18	0.24	0.32	0.22	0.28	0.34
95	0.48	0.15	0.19	0.24	0.16	0.20	0.25	0.20	0.23	0.27
120	0.38	0.13	0.17	0.20	0.14	0.17	0.21	0.18	0.21	0.23
150	0.31	0.12	0.15	0.17	0.13	0.15	0.18	0.17	0.19	0.20
185	0.25	0.11	0.13	0.15	0.12	0.14	0.15	0.16	0.17	0.18
240	0.19	0.10	0.12	0.12	0.11	0.13	0.13	0.15	0.16	0.15
300	0.15	0.10	0.11	0.11	0.11	0.12	0.12	0.15	0.15	0.14
400	0.12	0.09	0.10	0.09	0.10	0.11	0.10	0.14	0.14	0.12

Single phase circuits: multiply the values by 2.

Example

A 132 kW motor consumes 233 A with a voltage of 400 V. It is supplied by 3 x 150 mm² copper monoconductor cables, 200 mm long (0.2 km).

- Under normal operating conditions, $\cos \varphi = 0.8 \rightarrow K_u 0.18$

$$\Delta u = 0.18 \times 233 \times 0.2 = 8.4 \text{ V or } 2.1\% \text{ of } 400 \text{ V.}$$

- With on-line start-up $\cos \varphi = 0.3$
and $I_d = 5 I_n = 5 \times 233 \text{ A} = 1165 \text{ A}$

$$K_u = 0.13$$

$$\Delta u = 0.13 \times 1165 \times 0.2 = 20.3 \text{ V or } 7.6\% \text{ of } 400 \text{ V.}$$

The conductor cross section is sufficient to meet the maximum voltage drop imposed by standard IEC 60 364.

Note: this calculation is valid for 1 cable per phase.

For n cables per phase, simply divide the voltage drop by n.

Switching devices

IEC 947 -1 & IEC 947 -3 manufacturing standards

Definitions

Switch (IEC 947 -3 & 2.1)



"A mechanical connection device capable of:

- making, carrying and breaking currents under normal circuit conditions (a), possibly including specified operating overload conditions.
- carrying currents in abnormal circuit conditions - such as short-circuit conditions - for a specified duration" (a switch may be able to make short-circuit currents, but it cannot break them).

(a) normal conditions generally correspond to the use of a piece of equipment at an ambient temperature of 40 °C for a period of 8 hours.

Disconnecter (IEC 947 -3 & 2.2)



"A mechanical switching device which, when open, complies with the requirements specified for the isolating function. This device can carry currents in normal circuit conditions as well as currents in abnormal conditions for a specified duration."

Disconnecter: (working definition) device without on-load making and breaking capacity.

Switch-disconnector (IEC 947 -3 § 2.3)



Switch, which in its breaking position meets the specific insulation conditions for a switch-disconnector.

Fuse switch-disconnector (IEC 947 -3 § 2.9)



Switch-disconnector in which one or more poles include an-in series fuse in a combined device.

Functions

Separation of contacts

As stipulated by the mechanical switching device standard IEC 947 -3, or IEC 364 -5 -537, all disconnection devices must ensure adequate contact separation of contacts.

Testing contact separation capacity as per standard IEC 947 -3 is carried out in three tests:

- the dielectric test will define sparkover resistance (U_{imp} : impulse withstand voltage) dependent on the distance of the air gap between contacts. (Generally $U_{imp} = 8 \text{ kV}$ for $U_e = 400/690 \text{ V}$),
- the measurement of leakage current (I_p) will define insulation resistance in the open position partly depending on the creepage distances. At 110% of U_e , $I_p < 0.5 \text{ mA}$ (new device) and $I_p < 6 \text{ mA}$ (device at end of life span),
- checking the strength of the actuator and the position indication device is aimed at validating the "mechanical" reliability of position indications. The device is locked in the "I" position, and a force three times the standard operating force is applied to the operating mechanism.

During the course of this test, locking the device on the "O" position must not be possible, nor should the device remain in the "O" position after the test. This test is not necessary when contact opening is shown by other means than an operating mechanism, such as a mechanical indicator, or direct visibility of contacts, etc.

This third test meets the definition of "fully visible" breaking required by the decree of 14 November 1988 to provide the isolation function in low voltage B systems ($500 \text{ V} < U \leq 1000 \text{ V AC}$ and $750 \text{ V} < U \leq 1500 \text{ V DC}$). The latter characteristic is required by NF C 15-100 except for SELV or PELV ($U \leq 50 \text{ V AC}$ or 120 V DC).

On-load and overload breaking

This is ensured by devices defined for making and breaking in normal load and overload conditions. Type tests characterise devices able to make and break specific loads. These can have high overload currents under a low $\cos \varphi$ (a starting motor or a locked rotor).

The type of load or load duty defines the device's **load duty category**.

Breaking action in the event of a short-circuit

A switch is not intended to cut off a short-circuit current. However its dynamic withstand must be such that it withstands the fault until it is eliminated by the corresponding protective device.

On fused switches, the short-circuit is cut off by the fuses (see chapter Fuses p. D.44) with the considerable advantage of limiting high fault currents.

DEVICE \ ACTIONS				
Marking				
Withstanding				
Breaking				

(1) Not imposed by standard

(2) By the fuse

- Normal current
- Overload current
- Short-circuit current

IEC 947 -1 & IEC 947 -3 manufacturing standards (continued)

Characteristics

Application condition and utilization category, according to standard IEC 947 -3

Table A

UTILIZATION CATEGORY		USE	APPLICATION
AC AC20	DC DC20	Off-load making and breaking	Disconnectors ⁽¹⁾
AC21	DC21	Resistive loads including moderate overloads.	Switches at installation head or for resistive circuits (heating, lighting, except discharge lamps, etc.).
AC22	DC22	Inductive and resistive mixed loads including moderate overloads.	Switches in secondary circuits or reactive circuits (capacitor banks, discharge lamps, shunt motors, etc.).
AC23	DC23	Loads made of motors or other highly inductive loads.	Switches feeding one or several motors or inductive circuits (electric carriers, brake magnet, series motor, etc.).

(1) Today these devices are replaced by load break switches for obvious safety of use reasons.

Breaking and making capacities

Unlike circuit breakers, where these criteria indicate tripping or short-circuit making characteristics and perhaps requiring device replacement, switch making and breaking capacities correspond to utilization category maximum performance values.

In such extreme uses, the switch must still maintain its characteristics, in particular its resistance to leakage current and temperature rise.

Table B

	MAKING		BREAKING		N° OF OPERATING CYCLES
	I/I _e	COS φ	I/I _e	COS φ	
AC 21	1.5	0.95	1.5	0.95	5
AC 22	3	0.65	3	0.65	5
AC 23 I _e ≤ 100 A	10	0.45	8	0.45	5
I _e > 100 A	10	0.35	8	0.35	3
		L/R (ms)		L/R (ms)	
DC 21	1.5	1	1.5	1	5
DC 22	4	2.5	4	2.5	5
DC 23	4	15	4	15	5

Electrical and mechanical endurance

This standard establishes the minimum number of electrical (at full load) and mechanical (off-load) operating cycles that must be performed by devices. These characteristics also specify the device's theoretical lifespan during which it must maintain its characteristics, particularly resistance to leakage current and temperature rise.

This performance is linked to the device's use and rating. According to anticipated use, two additional application categories are offered:

- category A: frequent operations (in close proximity to the load)
- category B: infrequent operations (at installation head or wiring system).

Table C

I _e (A)	≤ 100	≤ 315	≤ 630	≤ 2500	> 2500
N° CYCLES/HOUR	120	120	60	20	10
N° OF OPERATIONS IN CAT. A					
without current	8500	7000	4000	2500	1500
with current	1500	1000	1000	500	500
Total	10000	8000	5000	3000	2000
N° OF OPERATIONS IN CAT. B					
without current	1700	1400	800	500	300
with current	300	200	200	100	100
Total	2000	1600	1000	600	400

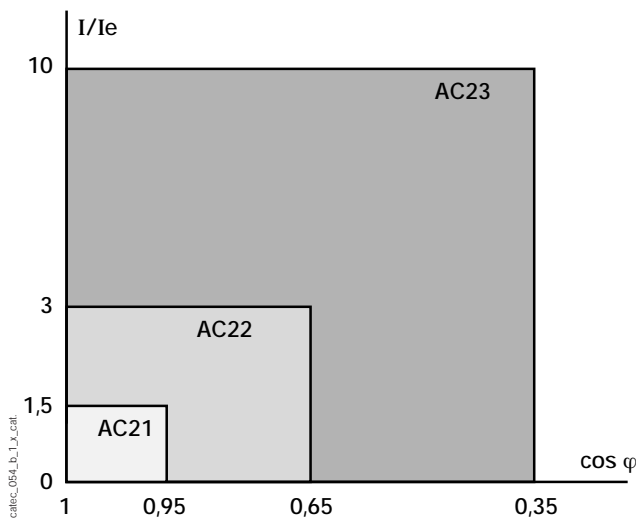

Fig. 1: making and breaking capacities

Operational Current I_e

Operational current is determined by endurance tests (both mechanical and electrical), and by making and breaking capacity tests.

Short circuit characteristics

- short-time withstand current (I_{cw}): Admissible rms current lasting for 1 second.
- short circuit making capacity (I_{cm}): peak current value which the device can withstand due to short circuit closure.
- conditional short circuit current: the rms current the switch can withstand when associated with a protection device limiting both the current and short circuit duration.
- dynamic withstand: peak current the device can support in a closed position.

The characteristic established by this standard is the short-time withstand current (I_{cw}) from which minimal dynamic withstand is deduced. This essential withstand value corresponds to what the switch can stand without welding.

Switching devices

Installation standards IEC 60364 and IEC 60204

▶ Isolating

This function is designed to ensure disconnection of the total or partial installation from the power supply for safety reasons.

The isolating function requires actions as follows:

- **breaking across all live conductors,**
- **assured off-load breaking,** provided additional measures (such as pre-break auxiliary contact, “do not operate on-load” indicator panel, etc.) are in place to ensure that the operational current is not cut on-load. For greater safety, a switching device able to break on-load as well as isolate may be used,
- **contacts separation.**

▶ Switching off for mechanical maintenance

This function is designed to switch off and maintain a machine in the off position in order to carry out mechanical maintenance operations without risk of physical injury, or for longer shutoffs.

The devices should be easily identifiable and used appropriately.

The switching off function for mechanical maintenance requires actions as follows:

- **assured on-load breaking.** Since personnel performing maintenance are not necessarily qualified electricians, circuit breaking should be possible without having to ensure that the load is off, or that the device has the correct application category, etc.,
- **contacts separation.** This action ensures that the device will without fail prevent accidental machine power-on.

This function is also offered by a local safety-breaking enclosure.

In these enclosures, visible breaking switches are generally used where external switch verification is required. Visible breaking is used for greater safety for personnel working in hazardous areas, particularly on sites where mechanical risks are very high, and where a damaged handle would no longer safely indicate the switch position.

▶ Emergency switching

This function ensures disconnection of circuit terminals. The aim of this function is to disconnect loads, thus preventing risk of fire, burns or electric shock. This entails fast easy access and identification of device to be switched.

Fast intervention depends on installation site layout, the equipment being operated, or the personnel present.

The emergency breaking function requires actions as follows:

- **assured on-load breaking,**
- **breaking across all live conductors.**

▶ Emergency stop

This function differs from emergency switching in that it takes into account the risks connected with moving machine parts.

The emergency stop requires actions as follows:

- **assured on-load breaking,**
- **breaking across all live conductors,**
- **possible retention of the supply, for example, for braking of moving parts.**

▶ Functional switching

In terms of practical operation of an electrical installation, it should be possible to operate locally without disconnecting the entire installation. In addition to selective control, functional control also comprises commutation, load shedding etc.

The functional control function requires actions as follows:

- **assured on-load breaking,**
- **breaking across certain live conductors** (e.g. 2 out of 3 phases of a motor).

Choosing a switching device

Choice according to neutral arrangement

• Three-phase network with distributed neutral

ARRANGEMENT	NEUTRAL CROSS SECTION ≥ PHASE CROSS SECTION	NEUTRAL CROSS SECTION < PHASE CROSS SECTION
TT		
TNC		
TNS		
IT with neutral		

Pole to be broken
 Pole to be protected

(1) The neutral does not have to be protected if the neutral conductor is protected against short circuits by the phase protection device and if the maximum fault current on the neutral is much lower than the maximum admissible current for the cable (IEC 60364 § 473.3).

Switching devices

Table A

DEVICES	BREAKING		Changeover switches	Fuse combination unit	Tripping devices	Motorised devices
	visual	visible				
CMP	•	•			•	optional
SIDERMAT with fuse bases	•	•		•	•	
SIDER changeover switch	•	•	•			
SIRCO VM changeover switch	•	•	•			
COMO C	•		•			
COMO I	•					
COMO M	•					
IDE	•				•	
SIRCO VM	•	•				
SIRCO	•					optional
SIDER	•	•				optional
SIDER ND	•	•				
SIDERMAT	•	•			•	
SIRCOVER	•		•			
Motorised SIRCOVER	•		•			•
FUSERBLOC	•			•		
FUSERBLOC V	•	•*		•		
FUSOMAT	•	•*		•	•	

* except for 1250 A rating.

Application types in a DC network

The operational current characteristics indicated in the general catalogue are defined for fig. 2, except where "2-pole in series" is specified. In this case see fig. 3.

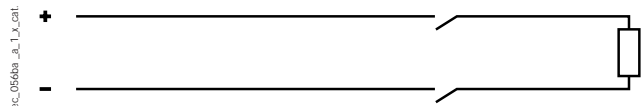

Fig. 2: 1 pole per polarity

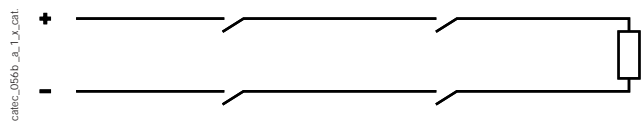

Fig. 3: 2 poles in series per polarity

Example 1: poles in series

A 400 A SIRCO device, used in a 500 V DC network with a 400 A operational current in DC 23 category, must have 2 poles in series per polarity.

Example 2: poles in parallel connecting precaution: ensure correct current distribution in both branches.

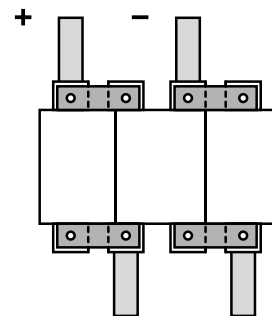

Fig. 4: poles in parallel

Switching devices

Uses

Protection

Circuit breaking time must be taken into account when using SIDERMAT or FUSOMAT tripping devices to protect against indirect contact and short circuits. The time between operation and effective contact breaking is less than 0.05 sec.

Power supply change over

The O - I or O - II operation time is 0.7 to 2.1 s depending on the devices.
The I - II switching time is 1.1 to 3.6 s.
(see details in chapter Motorised SIRCOVER).

Upstream of capacitor bank

Choose a switch rating 1.5 times higher than the nominal current value of the capacitor bank (I_c).

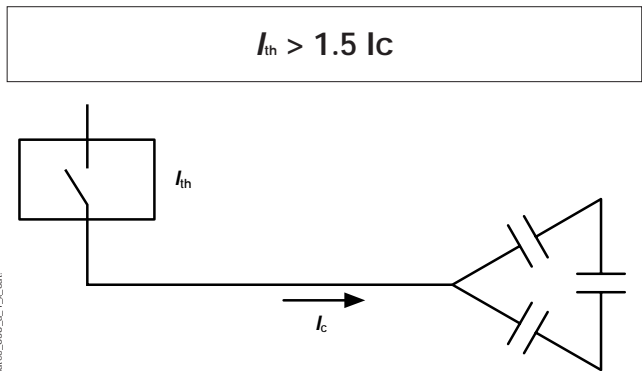

Fig. 1: switch upstream of capacitors

At transformer primary

Ensure that the switch making capacity is greater than the no-load current of the transformer.

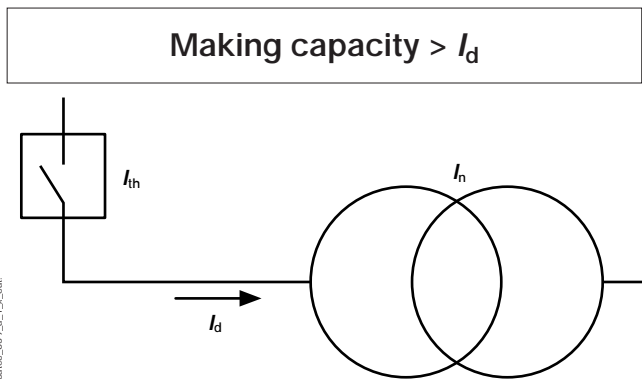

Fig. 2: switch at transformer primary

P kVA	50	100	160	250	400	630	1000	1250	1600
I _d / I _n	15	14.5	14	13	12	11	10	9	8.5

I_d: transformer no-load current
I_n: transformer nominal current

Upstream of motor

- For local security switching, the switch must be rated at AC23 to the nominal current (I_n) of the motor.
- In frequent start-up motor circuits, calculating the equivalent thermal current (I_{thq}) is necessary. Currents and start-up times vary widely according to motor inertia. For direct start-up they are generally between the following values:
 - peak current: 8 to 10 I_n
 - duration of peak current: 20 to 30 ms
 - start-up current I_d: 4 to 8 I_n
 - start-up time t_d: 2 to 4 sec.

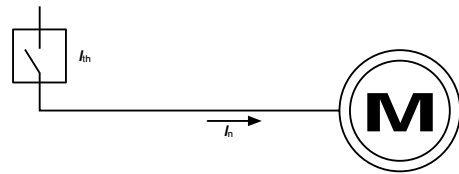

Fig. 3: switch upstream of motor

Examples of de-rating according to start-up type.

$$I_{thq} = I_n \times K_d \text{ and } I_{th} \geq I_{thq}$$

Table B

START UP TYPE	$\frac{I_d^{(4)}}{I_n}$	td ⁽⁴⁾ (s)	n ⁽¹⁾	Kd ⁽²⁾
direct up to 170 kW	6 to 8	0.5 to 4	n > 10	$\frac{\sqrt{n}}{3.16}$
Y - Δ (I _d /3)	2 to 2.5	3 to 6	n > 85	$\frac{\sqrt{n}}{9.2}$
direct - high inertia motors ⁽³⁾	6 to 8	6 to 10	n > 2	$\frac{\sqrt{n}}{1.4}$

(1) n: number of start-ups per hour for which de-rating is required.

(2) Kd: start-up factor ≥ 1

(3) fans, pumps, etc.

(4) average values very variable according to type of motor and receiver

- In cases of cyclic overloads (excluding start-ups). For specific machines (welding machines, motors), and generators with a peak cyclic current, the calculation of equivalent current (I_{thq}) is as follows:

$$I_{thq} = \sqrt{\frac{(I_1^2 \times t_1) + (I_2^2 \times t_2) + I_n^2 \times (tc - [t_1 + t_2])}{tc}}$$

I₁: overload current

I₂: possible intermediate overload

I_n: nominal operating current

t₁ and t₂: respective duration in seconds of currents I₁ and I₂

tc: cycle duration in seconds with lower limit set at 30 seconds

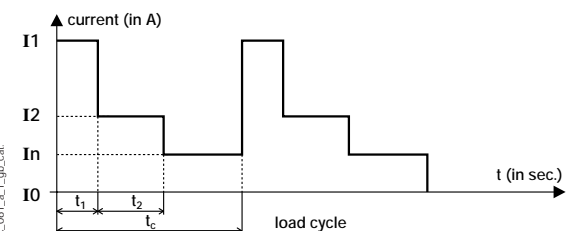

Fig. 4: cyclic overload

Correction factor

Certain operating conditions necessitate modification of thermal current using a correction factor.

► *Kt correction due to ambient air temperature*

Ambient air temperature surrounding the device

- Simplified method.

$$I_{thu} \leq I_{th} \times K_t$$

Table A: correction factors according to ambient air temperature t_a

Kt: correction factor	
0.9	40 °C < t_a ≤ 50 °C
0.8	50 °C < t_a ≤ 60 °C
0.7	60 °C < t_a ≤ 70 °C

- A more accurate calculation can be made for each application: please consult us.

Use with fuse combination unit

- Simplified method:
A switch must be de-rated by a factor of 0.8 when fuse bases are directly connected to its terminals.

Example: A 1250 A fuse set will consist of a 1600 A switch and 3 1250 A gG fuses

- A more accurate calculation can be made for each application: please consult us.

Other de-rating due to temperature

- switch fuses fitted with high speed fuses.
- in certain cases, de-rating is necessary for 24-hour full-load operation. Please consult us.

► *Kf correction due to frequency*

$$I_{thu} \leq I_{th} \times K_f$$

Table B: correction factors according to frequency f

Kf: correction factor	
0.9	100 Hz < f ≤ 1000 Hz
0.8	1000 Hz < f ≤ 2000 Hz
0.7	2000 Hz < f ≤ 6000 Hz
0.6	6000 Hz < f ≤ 10000 Hz

► *Ka correction factor due to altitude*

- No de-rating of I_{th}
- U_e and I_e de-rating in both AC and DC currents.

Table C: correction factors according to altitude A

	2000 m < A ≤ 3000 m	3000 m < A ≤ 4000 m
U_e	0.95	0.80
I_e	0.85	0.85

► *Kp correction due to device position*

Switches connection

As the entire SOCOMEC range of switches have a double breaking system per pole, the power source can be connected to the top or bottom of the device, except in those cases where regulations of identification stipulate power supply from below.

► *Kp correction due to device position*

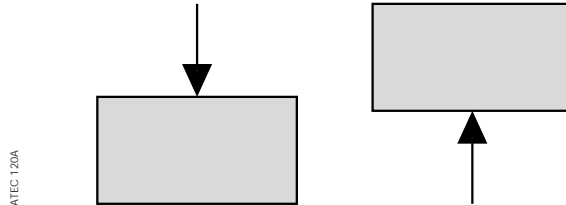

Fig. 1: direction of supply

Switch mounting and orientation

$$I_{thu} \leq I_{th} \times K_p$$

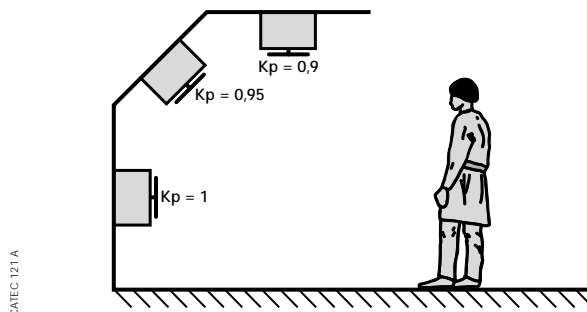

Fig. 2: position de-rating

Rotation of each device layout is limited either to clockwise or anti-clockwise in order to ensure that switching characteristics remain independent from the speed of operation.

Table D

			90° anti-clockwise	180°	90° clockwise
COMO M, COMO I, COMO C			YES	YES	YES
SIRCO VM	VM0, VM2	32 ... 40; 125 ... 160	YES	YES	YES
	VM1	63 ... 125	YES	YES	NO
SIRCO	3/4 pole	40 ... 3150 A	NO	YES	YES
		4000 A	YES	YES	NO
	6/8 pole	125 ... 630 A	YES	YES	NO
		800 ... 3150 A	NO	YES	YES
SIRCO UL		V 60 ... V 400 A	YES	YES	YES
SIDERMAT	Shunt trip coil	250 ... 1800 A	YES	YES	NO
	Undervoltage trip coil	250 ... 1800 A	NO	YES	YES
SIRCO VM1 changeover switches	I - 0 - II / I - I+II - II		YES	YES	NO
SIRCOVER	I - 0 - II	CD 125 ... CD 630 A	NO	YES	YES
		CD 800 ... 3150 A	YES	YES	NO
	I - I+II - II	CD 125 ... 3150 A	NO	YES	YES
		CD 125 ... CD 630 A	NO	YES	NO
SIRCOVER By-Pass	I - 0 - II	CD 125 ... CD 630 A	NO	YES	YES
		CD 800 ... 3150 A	YES	YES	NO
	I - I+II - II	CD 125 ... CD 630 A	NO	YES	YES
		CD 800 ... 3150 A	NO	YES	YES
Motorised SIRCOVER VE	I - 0 - II	250 ... 3150 A	YES	YES	NO
	I - I+II - II	250 ... 3150 A	NO	YES	YES
AtYS	I - 0 - II / I - I+II - II	125 ... 630 A	NO	YES	YES
FUSERBLOC Compact Design		CD 25 ... 1250 A	YES	YES	YES
FUSOMAT	Shunt trip coil	250 ... 1250 A	YES	YES	NO
	Undervoltage trip coil	250 ... 1250 A	NO	YES	YES

UL and NEMA specifications

General information about motor protection

► Typical construction of a motor starter

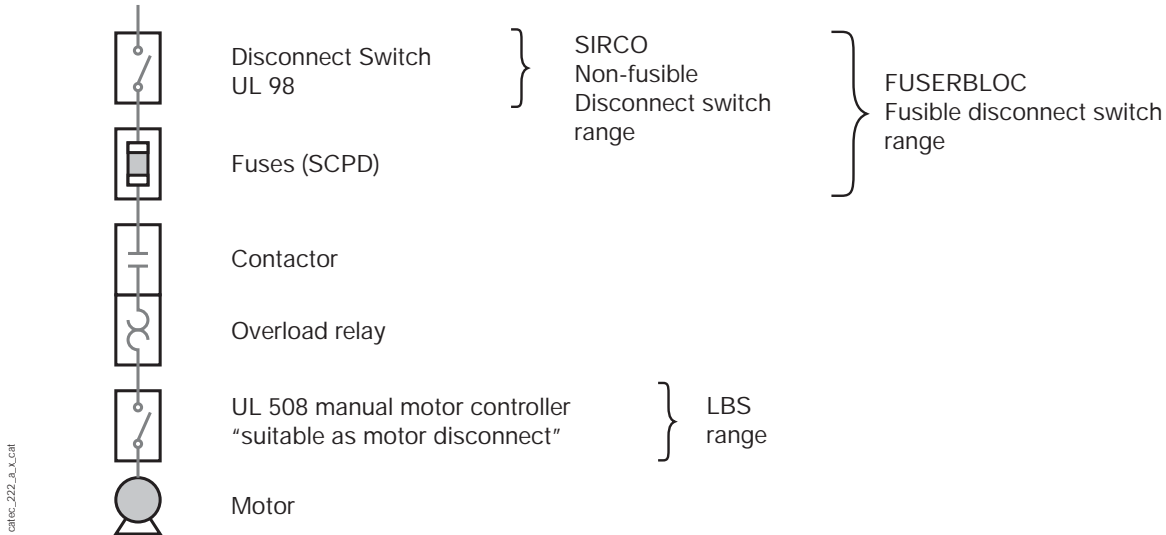

Essential parts of a motor branch circuit required by the national electrical code

- Disconnect means
- Branch-circuit short-circuit protective device
- Motor-controller
- Motor overload protective devices.

Disconnect means

The disconnect means can be a manual disconnect switch according to UL 98.

A manual motor controller (according to UL 508) additionally marked "suitable as motor disconnect" is only permitted as a disconnecting means where installed between the final branch-circuit short-circuit and ground-fault protective device and the motor (NEC 2002 Article 430.109).

Branch-circuit short-circuit protective device

The short-circuit protective device can be either a fuse or an inverse-time circuit-breaker.

Motor-controller

Any switch or device that is normally used to start and stop a motor according to the National Electrical Code article 430.81.

Motor overload protective devices

The national electrical code permits fuses to be used as the sole means of overload protection for motor branch circuits. This approach is often practical only with small single phase motors.

Most integral horsepower 3 phase motors are controlled by a motor starter which includes an overload relay. Since the overload relay provides overload protection for the motor branch circuit, the fuses may be sized for short-circuit protection.

General information about motor protection (continued)

► Wire size cross reference

AWG	mm ²	KCMIL/MCM	mm ²
14	2.1	250	127
12	3.3	300	152
10	5.3	350	177
8	8.4	400	203
6	13.3	500	253
4	21.2	600	304
3	26.7	700	355
2	33.6	750	380
1	42.4	800	405
1/0	53.5	900	456
2/0	67.4	1000	507
3/0	85.0	1250	633
4/0	107.2	1500	760
		1750	887
		2000	1014

► New NFPA 79 requirements and solutions

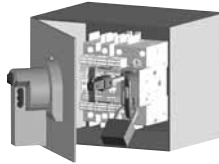

As defined in the NFPA 79 Standard section 5.3.3.1 and 6.2.3.1.2, our disconnecting devices fully comply with all of the following requirements:

1. Isolate the electrical equipment from the supply circuit and have one off (open) and one on (closed) position only.
2. Have an external operating means (e.g., handle).
3. Be provided with a permanent means permitting it to be locked in the off (open) position only (e.g., by padlocks) independent of the door position. When so locked, remote as well as local closing is prevented.
4. Be operable, by qualified persons, independent of the door position without the use of accessory tools or devices.

However the closing of the disconnecting means while door is open is not permitted unless an interlock is operated by deliberate action. Flange and side operation:

Our flange operated and side operated switches meet the requirements of the NFPA 79 without any additional parts being added.

► Nema ratings and IP cross-reference

NEMA TYPE	INTENDED USE AND DESCRIPTION	NEMA RATINGS AND IP CROSS-REFERENCE
1	Indoor use primarily to provide a degree of protection against contact with the enclosed equipment and against a limited amount of falling dirt	NEMA 1 meets or exceeds IP10
2	Indoor use to provide a degree of protection against a limited amount of falling water and dirt	NEMA 2 meets or exceeds IP11
3	Intended for outdoor use primarily to provide a degree of protection against rain, sleet, windblown dust, and damage from external ice formation.	NEMA 3 meets or exceeds IP54
3R	Intended for outdoor use primarily to provide a degree of protection against rain, sleet, and damage from external ice formation.	NEMA 3R meets or exceeds IP14
3S	Intended for outdoor use primarily to provide a degree of protection against rain, sleet, windblown dust, and to provide for operation of external mechanisms when ice laden.	NEMA 3S meets or exceeds IP54
4	Intended for indoor or outdoor use primarily to provide a degree of protection against windblown dust and rain, splashing water, hose-directed water, and damage from external ice formation.	NEMA 4 meets or exceeds IP56
4X	Intended for indoor or outdoor use primarily to provide a degree of protection against corrosion, windblown dust and rain, splashing water, hose-directed water, and damage from ice formation.	NEMA 4X meets or exceeds IP56
6	Intended for indoor or outdoor use primarily to provide a degree of protection against hose-directed water, the entry of water during occasional temporary submersion at a limited depth, and damage from external ice formation.	NEMA 6 meets or exceeds IP67
6P	Intended for indoor or outdoor use primarily to provide a degree of protection against hose-directed water, the entry of water during prolonged submersion at a limited depth, and damage from external ice formation.	NEMA 6P meets or exceeds IP67
12	Intended for indoor use primarily to provide a degree of protection against circulating dust, falling dirt, and dripping non-corrosive liquids.	NEMA 12 meets or exceeds IP52
12K	Type 12 with knockouts.	NEMA 12K meets or exceeds IP52

This table provides a guide for converting from NEMA enclosure type numbers to IP ratings. The NEMA types meet or exceed the test requirements for the associated European classifications; for this reason the table should not be used to convert "from IP rating to NEMA" and the "NEMA to IP rating" should be verified by test.

UL and NEMA specifications

Fusible disconnect switches' association chart with UL fuses (according to typical motor acceleration times)

► Three phase motor fuse and fusible disconnect switch selection UL class CC

MOTOR HP	FULL LOAD AMPERES	RECOMMENDED FUSE AMPERE RATING FOR TYPICAL* 5 SECS. MOTOR ACCELERATION TIMES		RECOMMENDED FUSIBLE DISCONNECT SWITCH	
		AMPERE RATING (A)		AMPERE RATING (A)	REFERENCE
208 V					
1/2	2.4	8		30	3710 3003 3712 3003 3712 6003 3716 3003 3716 6003
3/4	3.5	10			
1	4.6	15			
1-1/2	6.6	20			
2	7.5	20			
3	10.6	30			
240 V					
1/2	2.2	7		30	3710 3003 3712 3003 3712 6003 3716 3003 3716 6003
3/4	3.2	10			
1	4.2	12			
1-1/2	6	17-1/2			
2	6.8	20			
3	9.6	30			
480 V					
1/2	1.1	3-1/2		30	3710 3003 3712 3003 3712 6003 3716 3003 3716 6003
3/4	1.6	5			
1	2.1	6-1/4			
1-1/2	3	9			
2	3.4	10			
3	4.8	15			
5	7.6	25			
7-1/2	11	30			
600 V					
1/2	0.9	2-8/10		30	3710 3003 3712 3003 3712 6003 3716 3003 3716 6003
3/4	1.3	4			
1	1.7	5-6/10			
1-1/2	2.4	8			
2	2.7	8			
3	3.9	12			
5	6.1	17-1/2			
7-1/2	9	30			
10	11	30			

► Three phase motor fuse and fusible disconnect switch selection UL class J

MOTOR HP	FULL LOAD AMPERES	RECOMMENDED FUSE AMPERE RATING FOR TYPICAL* 5 SECS. MOTOR ACCELERATION TIMES		RECOMMENDED FUSIBLE DISCONNECT SWITCH	
		AMPERE RATING (A)		AMPERE RATING (A)	REFERENCE
208 V					
1/2	2.4	3-1/2		30	3710 3004 3712 3004 3712 6004 3716 3004 3716 6004
3/4	3.5	5			
1	4.6	7			
1-1/2	6.6	10			
2	7.5	10			
3	10.6	15			
5	16.7	25			
7-1/2	24.2	35			
10	30.8	45			
15	46.2	70			
20	60	90			
25	75	110		200	3712 3020 3712 6020 3716 3020 3716 6020
30	88	150			
40	114	175			
50	143	225			
60	169	250		400	3712 3040 3712 6040 3716 3040 3716 6040
75	211	350			
100	273	400			
125	343	500			
150	396	600		600	3712 3060 3712 6060

* Typical: suggested for most applications. Will coordinate with NEMA class 20 overload relays. Suitable for motor acceleration times up to 5 seconds.



Fusible disconnect switches' association chart with UL fuses (according to typical motor acceleration times)

► *Three phase motor fuse and fusible disconnect switch selection UL class J*

MOTOR HP	FULL LOAD AMPERES	RECOMMENDED FUSE AMPERE RATING FOR TYPICAL* 5 SECS. MOTOR ACCELERATION TIMES		RECOMMENDED FUSIBLE DISCONNECT SWITCH	
		AMPERE RATING (A)		AMPERE RATING (A)	REFERENCE
240 V					
1/2	2.2	3-1/2		30	3710 3004 3712 3004 3712 6004 3716 3004 3716 6004
3/4	3.2	5			
1	4.2	6-1/4			
1-1/2	6	9			
2	6.8	10			
3	9.6	15			
5	15.2	25		60	3716 3006 3712 6006 3716 3006 3716 6006
7-1/2	22	35			
10	28	40			
15	42	60		100	3712 3010 3712 6010 3716 3010 3716 6010
20	54	80		200	3712 3020 3712 6020 3716 3020 3716 6020
25	68	100			
30	80	125			
40	104	150		400	3712 3040 3712 6040 3716 3040 3716 6040
50	130	200			
60	154	225			
75	192	300		600	3712 3060 3712 6060
100	248	350			
125	312	450			
150	360	500			
480 V					
1/2	1.1	1-6/10		30	3710 3004 3712 3004 3712 6004 3716 3004 3716 6004
3/4	1.6	2-1/4			
1	2.1	3-2/10			
1-1/2	3	4-1/2			
2	3.4	5			
3	4.8	8			
5	7.6	12		60	3716 3006 3712 6006 3716 3006 3716 6006
7-1/2	11	17-1/2			
10	14	20			
15	21	30		100	3712 3010 3712 6010 3716 3010 3716 6010
20	27	40			
25	34	50			
30	40	60		200	3712 3020 3712 6020 3716 3020 3716 6020
40	52	80			
50	65	100			
60	77	125		400	3712 3040 3712 6040 3716 3040 3716 6040
75	96	150			
100	124	200			
125	156	225		600	3712 3060 3712 6060
150	180	250			
200	240	350			
250	302	450			
300	361	600			
600 V					
1/2	0.9	1-1/2		30	3710 3004 3712 3004 3712 6004 3716 3004 3716 6004
3/4	1.3	2			
1	1.7	2-1/2			
1-1/2	2.4	3-1/2			
2	2.7	4			
3	3.9	6			
5	6.1	10		60	3716 3006 3712 6006 3716 3006 3716 6006
7-1/2	9	15			
10	11	17-1/2			
15	17	25		100	3712 3010 3712 6010 3716 3010 3716 6010
20	22	35			
25	27	40			
30	32	50		200	3712 3020 3712 6020 3716 3020 3716 6020
40	41	60			
50	52	80			
60	62	90		400	3712 3040 3712 6040 3716 3040 3716 6040
75	77	125			
100	99	150			
125	125	200		600	3712 3060 3712 6060
150	144	225			
200	192	300			
250	240	350			
300	289	450			

* Typical: suggested for most applications. Will coordinate with NEMA class 20 overload relays. Suitable for motor acceleration times up to 5 seconds.

General characteristics

Introduction

Fuses are designed to break an electric circuit in cases of abnormal currents. They also have the added advantage of being able to limit high current faults (see example below).

The fuse's essential characteristics are its reliability in terms of protection, its simplicity and its economical price.

Optimising fuse choice depends on the fuse's technical features as follows:

- pre-arcing time**

This is the time necessary for the current to bring the fuse element to vaporisation point before melting.

Pre-arcing time is independent from network voltage.

- arcing time**

This is defined as the period between the instant of arc appearance and its total extinction (zero current). Arc time depends on network voltage, but is negligible compared to pre-arcing time for total melting time > 40 ms.

- operation time**

This is the sum of pre-arcing and arcing times.

- breaking capacity**

This is the prospective short circuit current value that the fuse can blow under a specified operational voltage.

- joule integral,** $\int_0^t I^2 dt$

This is the integral value of the current cut during total melting time, expressed as A²s (Amps squared seconds).

Short-circuit current cut-off

The two parameters to be considered for short-circuit current cut-off are:

- the true current peak reached in the protected circuit,
- the prospective rms current that would develop in the absence of fuses in the circuit.

Note: There is only one cut-off if $t_{pre-arcing} < 5$ ms (50 Hz network).

The cut-off current diagram indicates the correspondence between these two parameters (see pages D.47 and D.49).

The following actions should be performed to know peak current (which can increase in fuse-protected electric circuits):

- calculate maximum rms short-circuit current (see page D.21),
- plot this current value on the cut-off current diagram, and read off peak value according to the fuse rating protecting the circuit.

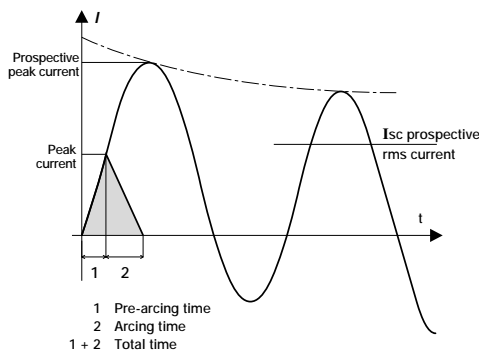

Fig. 1: short-circuit current cut-off

Short-circuit current cut-off (continued)

Example:

A symmetric 100 kA rms short-circuit current cut-off with 630 A gG fuse is required.

The prospective 100 kA rms current results in a prospective peak current as follows: $100 \times 2.2 = 220$ kA

The fuse cuts-off peak current at 50 kA (see fig. 2), representing 35% of its prospective value (see fig. 2) leading to a reduction of 13% of unprotected value in electrodynamic forces (see fig. 3), and a reduction in I²t limited to 2.1% of its value (see fig. 4).

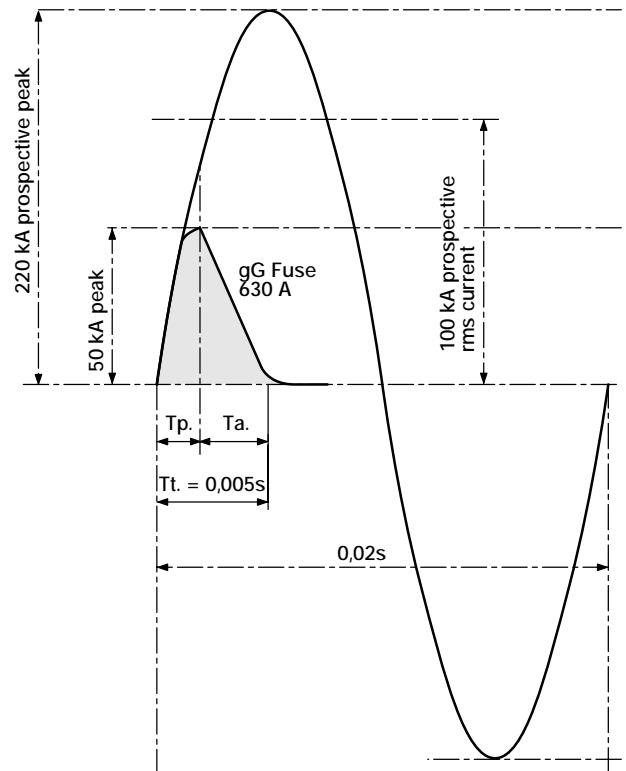

Fig. 2: cut-off peak current

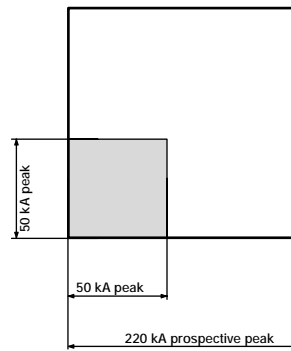

Fig. 3: limiting electrodynamic forces proportional to squared current

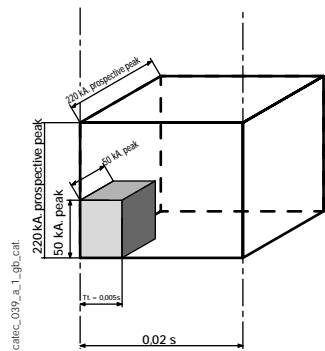

Fig. 4: limiting I²t 1 x 1 x t

callec_036_a_1_gp_cat

callec_037_a_1_gp_cat

callec_038_a_1_gp_cat

callec_039_a_1_gp_cat

Choosing “gG” and “aM” fuses

Three parameters should be taken into account when selecting a protection system:

- network characteristics,
- installation specifications,
- the circuit characteristics in question.

The calculations given hereafter are for information purposes only. Please contact us for equipment requiring special applications.

▶ Network characteristics

Voltage

A fuse can never be used with an rms voltage above its rated voltage. It operates normally at lower voltages.

Frequency

- **f < 5 Hz:** the operational voltage (U_e) is considered equivalent to DC voltage and $U_e = U_{peak}$
- **5 ≤ f < 48 Hz:**

$$U_e \leq k_u \times U_n$$

f (in Hz)	5	10	20	30	40
k_u	0.55	0.65	0.78	0.87	0.94

k_u : voltage de-rating coefficient due to frequency.

- **48 ≤ f < 1000 Hz:** no voltage de-rating.

Short circuit current

Once established, its values must be checked to ensure they are less than the fuses' breaking capacity:

- 100 kA rms for sizes 14 x 51, 22 x 58, T00, T0, T1, T2, T3, T4, T4A,
- 50 kA rms for sizes 10.3 x 38.

▶ Installation specifications

Earthing arrangements

Fuses have one or two protection functions according to the neutral load:

- against overcurrents: A,
- against indirect contact: B

ARRANGEMENT	PROTECTION
TT	A
IT	A + B
TNC	A + B
TNS	A + B

▶ Circuit features

Fuse use is limited according to ambient temperature (t_a) surrounding the device.

$$I_{th} u \leq I_n \times K_t$$

$I_{th} u$: operating thermal current: maximum permanent current accepted by the device for 8 hours in specific conditions

I_n : fuse rated current

K_t : coefficient given in table below

t_a	K_t			
	gG fuse		aM Fuse	
	FUSE BASE	EQUIPMENT AND COMBINATION	FUSE BASE	EQUIPMENT AND COMBINATION
40 °	1	1	1	1
45 °	1	0.95	1	1
50 °	0.93	0.90	0.95	0.95
55 °	0.90	0.86	0.93	0.90
60 °	0.86	0.83	0.90	0.86
65 °	0.83	0.79	0.86	0.83
70 °	0.80	0.76	0.84	0.80

If the fuse is installed in a ventilated enclosure K_t and K_v values must be multiplied.

- Air speed $V < 5$ m/sec. $K_v = 1 + 0.05 V$
- Air speed $V \geq 5$ m/sec. $K_v = 1.25$

Example: A gG fuse is mounted in a base within a ventilated enclosure

- temperature in the enclosure: 60 °C
- air speed: 2 m/sec.

$$K_v = 1 + 0.05 \times 2 = 1.1$$

$$K_t = 1.1 \times 0.86 = 0.95$$

Choosing "gG" and "aM" fuses (continued)

► Circuit features (continued)

Precautions for use at altitudes > 2000 m

- No current de-rating
- Breaking capacity is limited. Please consult us.
- Size de-rating is recommended.

Upstream of isolating transformer

Switching on an off-load transformer triggers a large current inrush. An aM fuse will be needed at primary coil which is able to withstand repeated overload. The secondary will be protected by gG fuses.

Upstream of motor

Motor protection is usually ensured by thermal relay. The protection of motor power supply conductors is ensured by aM or gG fuses. Table A shows fuse ratings to be linked to thermal relay according to motor power.

Note:

- Motor nominal current varies from one manufacturer to another. Table A shows standard values.
- aM fuses are preferred to gG fuses for this application.
- In cases of frequent or heavy start-up (direct start-up > 7 I_n for more than 2 seconds or start-up > 4 I_n for more than 10 seconds), it is recommended to select a bigger size than that indicated in the table. It will nevertheless be necessary to check to co-ordination of selectivity between the fuse and the circuit breaker (see page D.52).
- In cases of aM fuse melting, replacing the fuses all three phases is advised.

Table A: protecting motors with aM fuses

MOTOR										RA-TINGS	RECOM-MENDED SIZE	ASSOCIATED FUSE SWITCH RECOMMENDED SIZE
400 V tri			500 V tri									
Kw	Ch	In A	Kw	Ch	In A							
7.5	10	15.5	11	15	18.4	20	10 x 38 or 14 x 51	FUSERBLOC 32 A CD				
11	15	22	15	20	23	25	10 x 38 or 14 x 51					
15	20	30	18.5	25	28.5	40	14 x 51	FUSERBLOC 50 A				
18.5	25	37	25	34	39.4	40	14 x 51					
22	30	44	30	40	45	63	22 x 58	FUSERBLOC 100 A or 125 A				
25	34	51	40	54	60	63	22 x 58					
30	40	60	45	60	65	80	22 x 58					
37	50	72	51	70	75	100	22 x 58					
45	60	85	63	109	89	100	22 x 58					
55	75	105	80	110	112	125	T 00	FUSERBLOC 160 A				
75	100	138	110	150	156	160	T 0					
90	125	170	132	180	187	200	T 1	FUSERBLOC 250 A				
110	150	205	160	220	220	250	T 1					
132	180	245	220	300	310	315	T 2	FUSERBLOC 400 A				
160	218	300				315	T 2					
200	270	370	250	340	360	400	T 2					
250	340	475	335	450	472	500	T 3	FUSERBLOC 630 A				
315	430	584	450	610	608	630	T 3					
400	550	750	500	680	680	800	T 4	FUSERBLOC 1250 A				

Upstream of capacitor bank

Fuse rating must be greater than, or equal to, twice the nominal current of the capacitor bank.

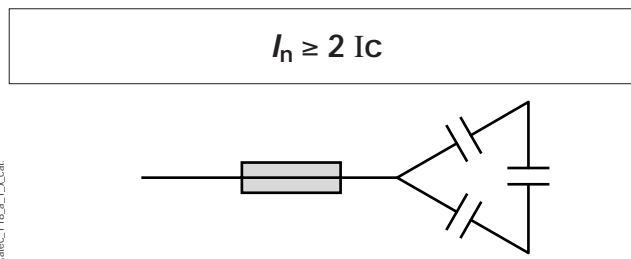
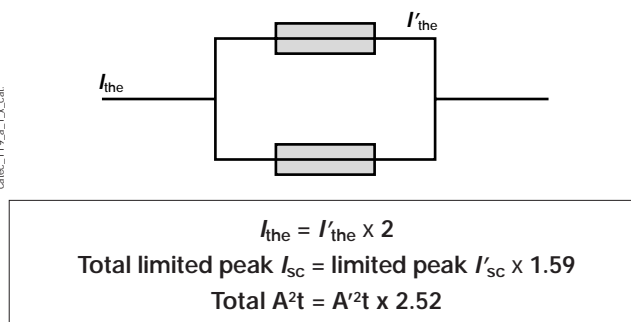

Table B: fuse rating for 400 V capacitor bank

Capacity in kvar	5	10	20	30	40	50	60
gG fuse in A	20	32	63	80	125	160	200
Capacity in kvar	75	100	125	150			
gG fuse in A	200	250	400	400			

Connecting fuses in parallel

Connecting fuses in parallel is only possible between two fuses of the same size and rating.



I'_{the} : temperature stress.

► Use in DC

DC pre-arcing time is identical to AC pre-arcing time. Time/current characteristics and the cut-off current remain valid for the use of fuses in AC. On the other hand, arcing time is much higher in DC because there is no return to 0 voltage

MAXIMUM VOLTAGE	
In AC	In DC
400 V	260 V
500 V	350 V
690 V	450 V

Employing bigger fuses than usual is recommended, whereas the rating remains the same; sizes 10 x 38 and 14 x 51 being reserved for circuits ≤ 12 A.

For highly inductive circuits, placing two fuses in series on the + pole is recommended.

It is not possible to use aM fuses in DC.

Curves characteristic of "gG" fuses

► *Cut-off current diagram*

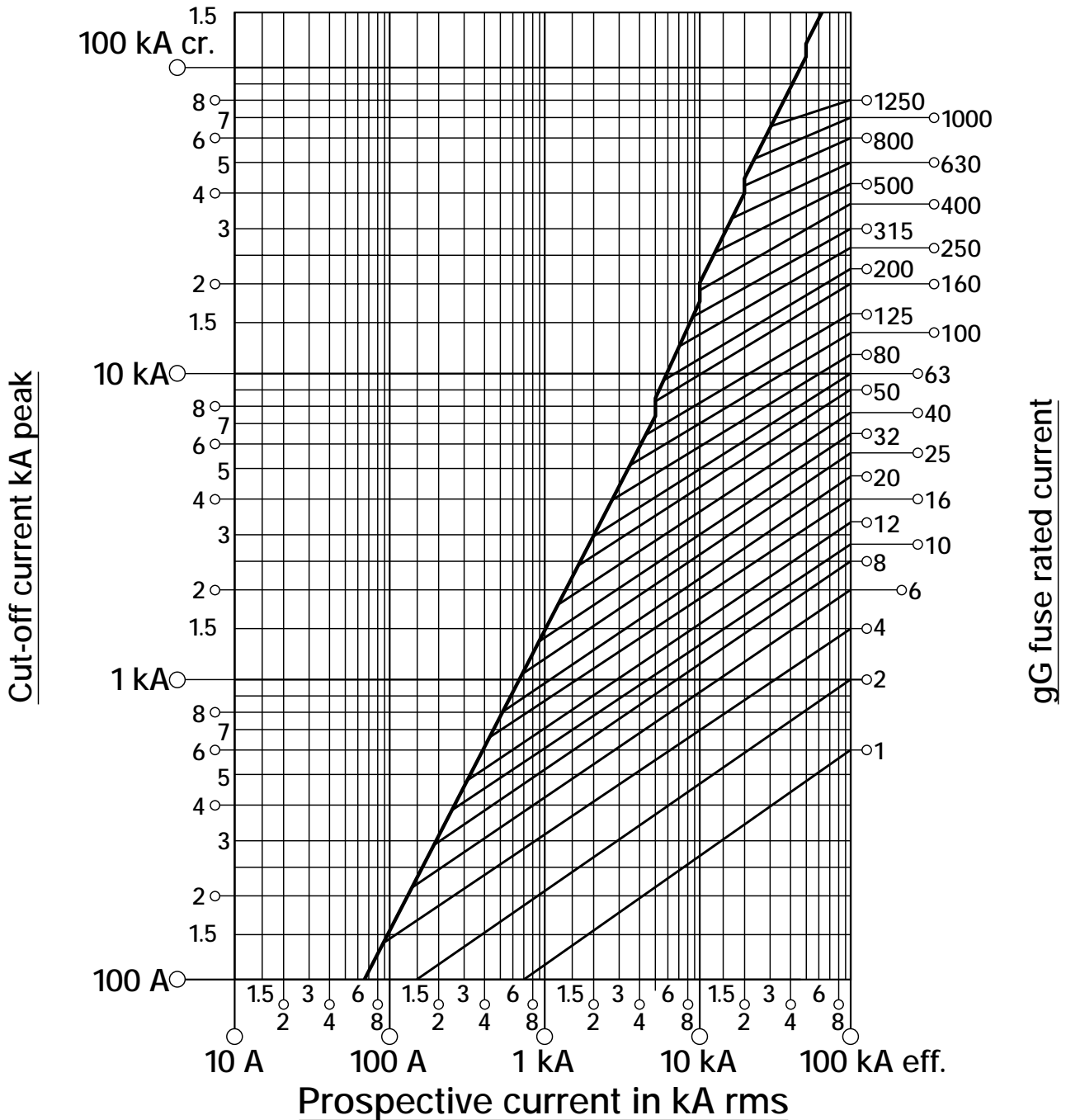

Fuses

Curves characteristic of "gG" fuses (continued)

► **Diagram of thermal constraint limitation**

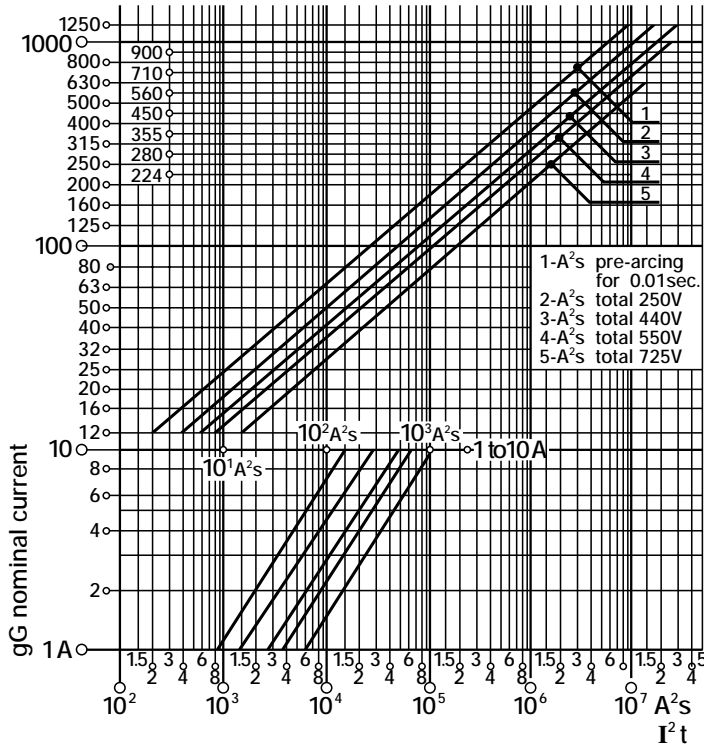

► **Time/current operation characteristics (IEC or BS standard)**

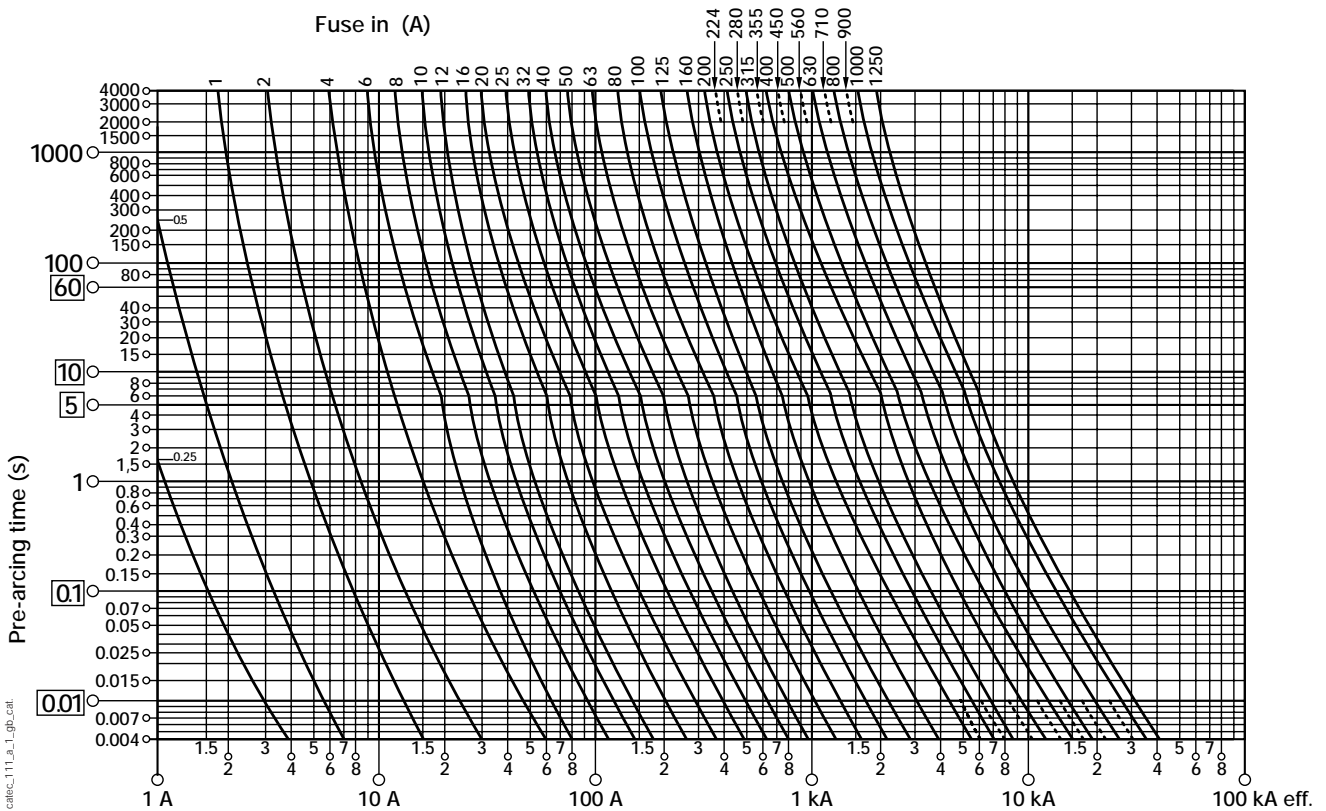

Curves characteristic of "aM" fuses

► Current cut-off diagram

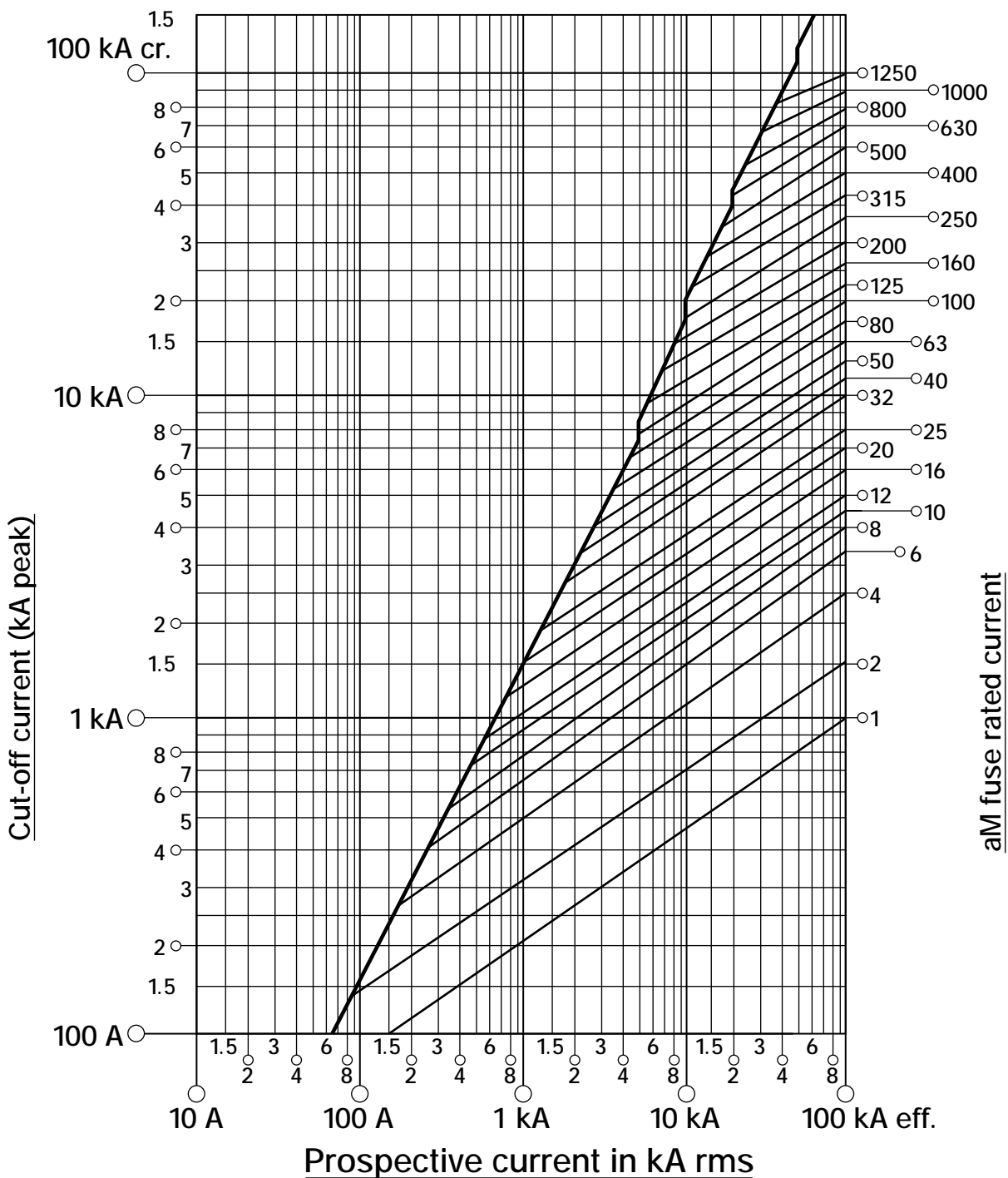

cathec_114_b_1_gbr.pdf

Fuses

Curves characteristic of "aM" fuses (continued)

► Diagram of thermal constraint limitation

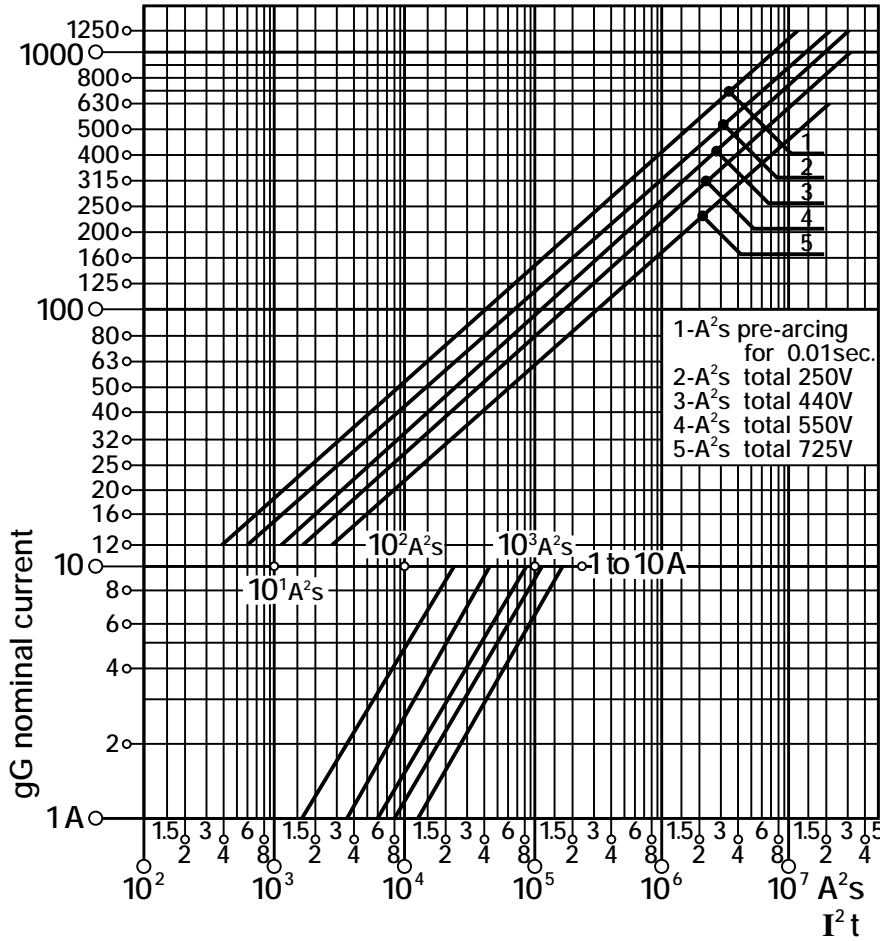

catrec_115_a_1_gb_cat

► Time/current characteristics (IEC standard)

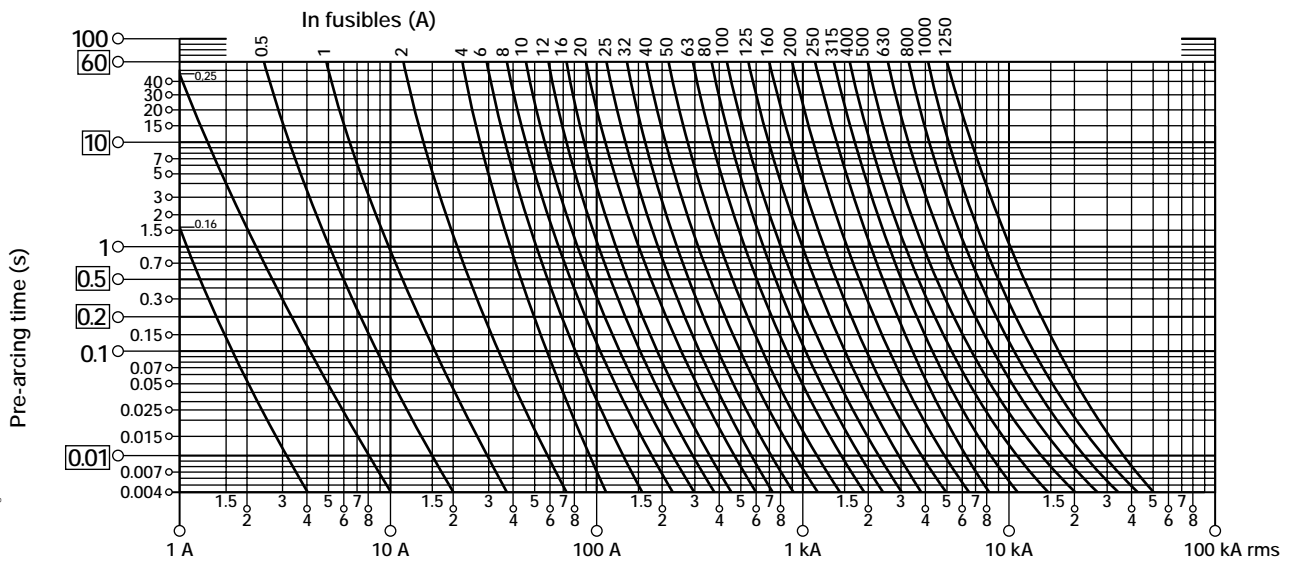

catrec_113_a_1_gb_cat

High speed fuses

These ultra fast fuses ensure protection against short circuit currents. Due to their design, total operation time is much faster than gG and aM fuses. They are generally used for power semiconductors (I^2t "high speed" < I^2t of the semiconductor to be protected).

Overloading ($I \sim 2 I_n$, $t \geq 100$ seconds) must be avoided. If necessary, protecting against overloads must be ensured by another device. High speed fuse determination involves a rigorous procedure which can be complex for certain applications. The method below represents a first step.

Please consult us for any specific application.

► Choosing "high speed" fuses

Temperature stress

High speed fuses are designed to protect semiconductor devices; Each semiconductor device has a specified maximum I^2t , and this is the most important factor to be considered when choosing the correct fuse, rather than the thermal rating. For effective protection, the fuse I^2t must be about 20% less than the semiconductor's rupturing I^2t .

Example: a 30 A/400 V diode withstands a maximum I^2t of 610 A²s. The associated high speed fuses maximum I^2t will be 610 - 20% = 488 A²s with 400 V.

Voltage

I^2t (see general catalogue) is usually given for 660 V. Use with a different voltage requires the following correction:

$$(i^2t) V = K_v \times (i^2t) 660 V$$

Example: for U = 400 V $K_v = 0.6$
 $(i^2t) 400 V = 0.6 \times (i^2t) 660 V$

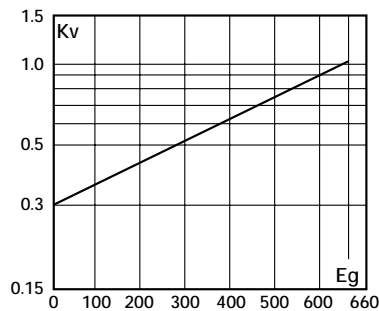

Fig. 1: K_v correction factor

K_v : I^2t correction factor

E_g : operating voltage rms value

Power factor: The I^2t indicated in the general catalogue is given for a power factor of 0.15 (cos. φ of default circuit). For other power factor values, multiplying the I^2t value by K_y value is necessary.

POWER FACTOR	0.1	0.15	0.2	0.25	0.30	0.35	0.40	0.45	0.50
K_y	1.04	1.00	0.97	0.93	0.90	0.87	0.85	0.82	0.81

Nominal current

Once the fuse's maximum I^2t has been established, the circuit's nominal current value must then be taken into account.

Example: in the previous example, the high speed fuse's maximum I^2t was established thus: 488 A²s at 400 V. At 660 V this value is worth: 488/0.62 = 787 A²s. The circuit current is 20 A.

Note that with a 25 A high speed fuse where I^2t at 660 V, the value is 560 A²s.

► Choosing "high speed" fuses (continued)

Correction according to ambient temperature

High speed fuse rating is given for an ambient temperature of 20 °C. Maximum operating current I_b is given by:

$$I_b = K_{TUR} \times (1 + 0.05 v) \times I_n$$

- I_n : fuse's rated current in A.
- s : speed of cooling air in m/s.
- K_{TUR} : value given by figure 2 according to air temperature in fuse proximity.

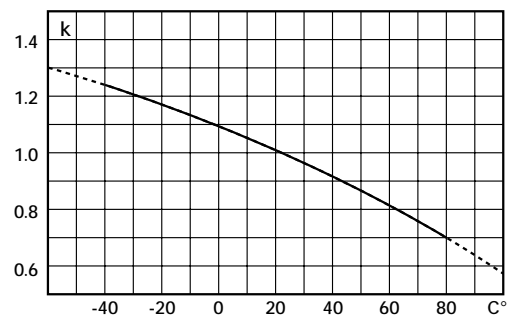

catrec_034_a_1_ghb_cat

Fig. 2: K_{TUR} correction factor

Series connection

This is not recommended when the fault current is insufficient to melt the fuse in less than 10 ms.

Parallel connection

Placing fuses in parallel is possible between two fuses of the same size and rating. This is usually carried out by the manufacturer.

In cases of parallel connection, care must be taken that the operating voltage does not exceed 90% of the fuse's nominal voltage.

Cyclic overload

Please consult us.

Loss in Watts

These are given in the general catalogue and correspond to power loss with nominal current.

To use an I_b current different from I_n , the loss in Watts must be multiplied by the K_p value given in the figure below.

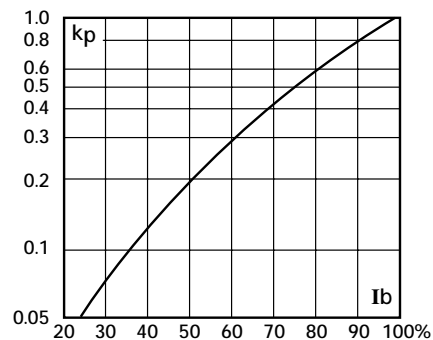

catrec_035_a_1_ghb_cat

Fig. 3: K_p correction value

K_p : loss correction value

I_b : load current rms value in% of nominal current.

Discrimination

► Discrimination between fuses

Fuses discrimination between LV and HV

Operating an LV fuse must not result in melting of the HV fuse placed at the HV/LV transformer primary.

In order to avoid this, it is necessary to check that the lower part of HV curve never crosses the upper part of the LV curve before the LV I_{sc} maximum limit (See calculation page D.22).

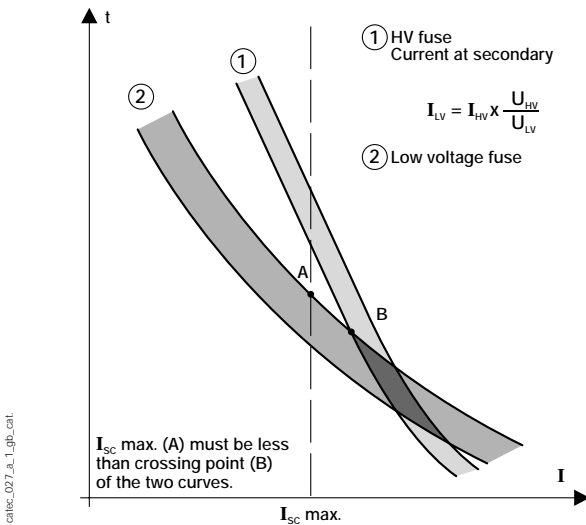

Fig. 1: discrimination between HV and LV fuses

Discrimination on a network powered by UPS (Uninterruptible Power Supply)

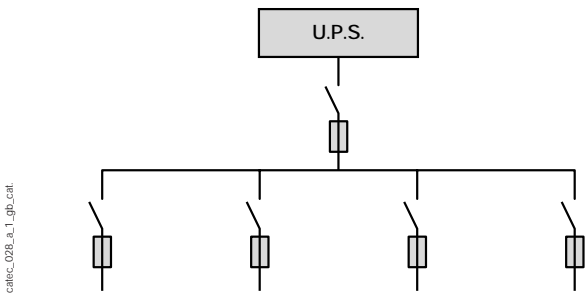

Fig. 2: network powered by UPS

Protection devices discrimination is highly important on networks powered by UPS, where protection tripping must not cause any disturbance on the rest of the network.

Discrimination must take into account two properties of these networks:

- low fault current (approx. $2 \times I_n$)
- maximum fault time generally set at: 10 ms

To comply with these criteria and ensure correct discrimination, the current in each branch must not exceed the values in the table below:

PROTECTION BY	MAX. STARTING CURRENT
gG fuse	$\frac{I_n}{6}$
High speed fuse	$\frac{I_n}{3}$
Small circuit breakers	$\frac{I_n}{8}$

► Discrimination between fuse and overcurrent switch

The fuse is placed upstream of the overcurrent switch. An overcurrent switch consists of a contactor and a thermal relay.

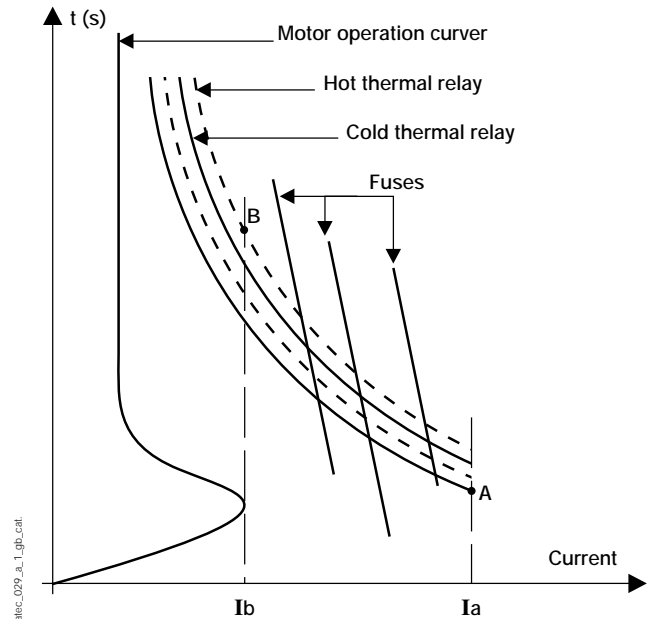

Fig. 3: discrimination between fuses and overcurrent switch

The curves of fuses linked of the overcurrent switch must pass through point A and B corresponding to:

- I_a : overcurrent switch's breaking capacity
- I_b : motor start-up current

START-UP TYPE	$I_b^{(1)}$	START-UP TIME ⁽¹⁾
Direct	$8 I_n$	0.5 to 3 sec.
Star-delta start	$2.5 I_n$	3 to 6 sec.
Stator start	$4.5 I_n$	7 to 12 sec.
Autotransformer start	1.5 to $4 I_n$	7 to 12 sec.
Rotor start	$2.5 I_n$	2.5 to 5 sec.

(1) average values may vary considerably according to the type of motor and receiver.

The fuse's temperature stress must be less than that of the overcurrent switch.

Amongst the different fuse ratings available, choose the highest rating in order to minimise power dissipation.

Discrimination (continued)

► Discrimination between circuit breaker and fuse

The judicious combination of a fuse with other devices (circuit breakers, etc.) provides perfect discrimination and offers optimum economy and safety.

Fuse upstream – circuit breaker downstream

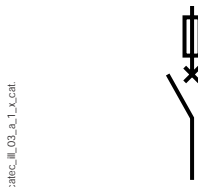

- The fuse's pre-arcing melting curve must be placed above point A (fig. 1).
- The fuse's complete blowing curve must cut the circuit breaker's curve before the circuit breaker's I_{sc} value (ultimate breaking capacity).
- After the crossover point, the fuse's I^2t must be less than that of the circuit breaker.
- The fuse's and circuit breaker's I^2t must always be less than that of the cable.

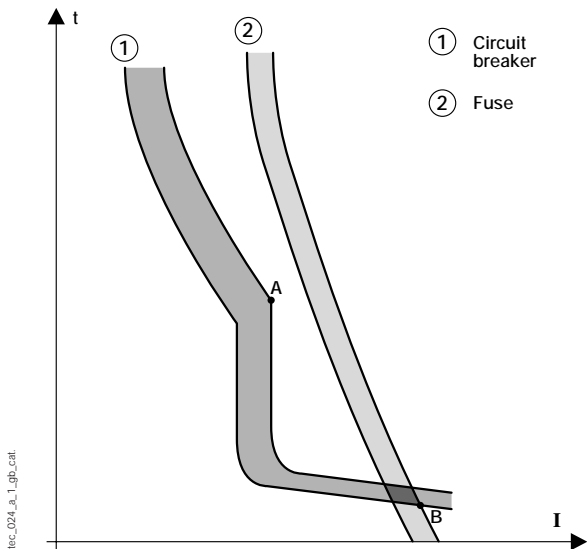
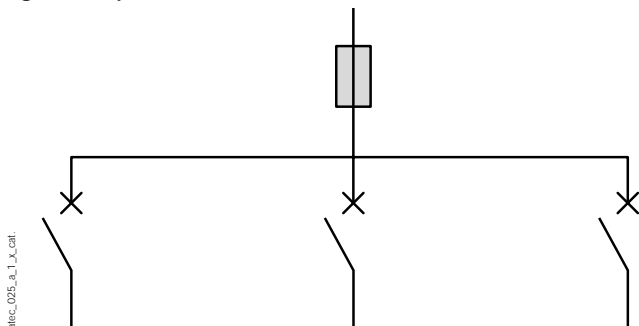

Fig. 1: fuse/circuit breaker discrimination

gG fuse upstream – several circuit breakers downstream



- Fuse rating must be greater than the sum of circuit breaker currents simultaneously on load.
- Fuse blowing curve must be above point A of the circuit breaker with the highest rating.

- Crossover point B (see fig. 1) must be less than the circuit breaker's lowest ultimate breaking capacity.
- After point B, the fuse's total I^2t must be less than any upstream circuit breaker's I^2t .

Circuit breaker upstream – several fuses downstream

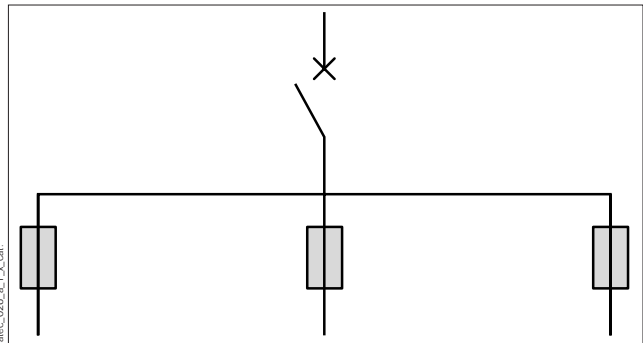

- The breaking capacity of all fuses and circuit breakers must be greater than maximum short circuit current possible in the circuit.
- The thermal setting of the circuit breaker (I_t) must be such that:
 $1.05 I_t \geq I_1 + I_2 + \dots + I_n$
 $I_1 + I_2 + \dots + I_n$: sum of currents protected by fuse in each branch.
- I_t current setting must also meet the following condition:

$$I_t \geq K_d \times I_n$$

I_n : fuse rating of the circuit with the highest load.

Table A: K_d values (according to IEC 269-2-1)

gG FUSE RATING (I_n) (A)	K_d
$I_n \leq 4$	2.1
$4 < I_n < 16$	1.9
$16 \leq I_n$	1.6

Example: the circuit with the highest load is protected by a 100 A gG fuse. The upstream circuit breaker's minimum setting current enabling fuse discrimination will be:

$$I_t \geq 1.6 \times 100 \text{ A} = 160 \text{ A.}$$

- The highest rated fuse's I^2t must be less than the I^2t limited by circuit breaker. The latter must be less than the cables' maximum I^2t .
- I_m (magnetic) minimum setting value.
 $8 K_d \leq I_m \leq 12 K_d$
 K_d is given in table A.

Discrimination (continued)

General points

In cases of fault on any installation point, protection discrimination is ensured when the protection device (PD) opens directly upstream of the fault, without triggering the breaking of other devices in the entire installation. Discrimination permits continuous operation on the rest of the network.

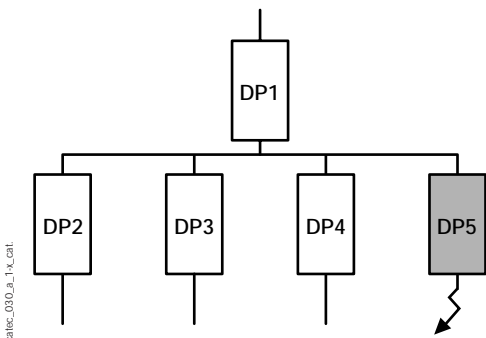

Fig. 1: a fault at point A must trigger the breaking of the protection device PD5 without breaking any other PD

- Total discrimination is ensured when time/current zones characterising protection devices do not overlap.

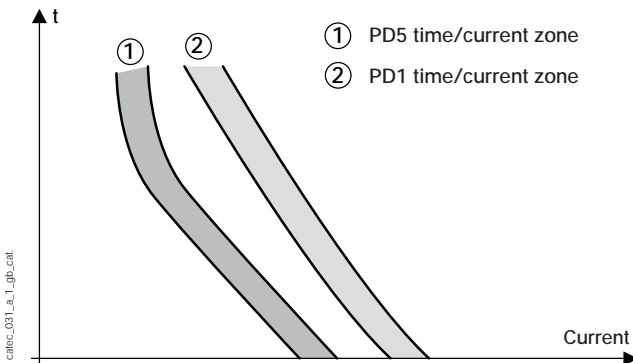

Fig. 2: total discrimination

- Partial discrimination consists of limiting the PD discrimination in one part only of their time/current zone. Where the default current is less than the curves' crossover points, the result is total discrimination.

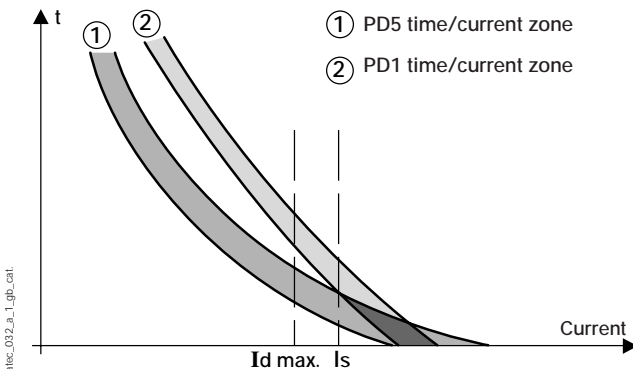

Fig. 3: partial discrimination

Discrimination between fuses

gG and aM fuses discrimination

Total discrimination is ensured by choosing fuses in tables A and B (according to IEC 269 -1 and 269 -2 -1).

However, in certain uses partial discrimination may suffice.

Table A

UPSTREAM FUSE	DOWNSTREAM FUSE	
gG	gG	aM
Ratings (A)		
4	1	1
6	2	2
8	2	2
10	4	2
12	4	2
16	6	4
20	10	6
25	16	8
32	20	10
40	25	12
50	32	16
63	40	20
80	50	25
100	63	32
125	80	40
160	100	63
200	125	80
250	160	125
315	200	125
400	250	160
500	315	200
630	400	250
800	500	315
1000	630	400
1250	800	500

Table B

UPSTREAM FUSE	DOWNSTREAM FUSE	
aM	gG	aM
Ratings (A)		
4	4	2
6	6	2
8	8	4
10	10	6
12	4	2
16	16	10
20	20	12
25	25	12
32	32	20
40	32	25
50	40	25
63	50	40
80	63	50
100	80	63
125	100	80
160	125	100
200	160	125
250	160	160
315	200	200
400	250	250
500	315	315
630	400	400
800	500	500
1000	500	630
1250	630	800

gG/High speed fuses discrimination

- gG upstream - high speed downstream: High speed fuse's pre-arcing time must be less than half of the gG fuse's pre-arcing time, between 0.1 and 1 second.
- High speed upstream - gG downstream: High speed fuse rating must be at least equal to 3 times the rating of the gG fuse.

Energy management

DIRIS and COUNTIS

Functions and applications

► Introduction

The COUNTIS system is used for energy metering. The DIRIS system is used for measuring electrical quantities, metering and energy management⁽¹⁾, monitoring, control/command and the protection of the installations.

All these functions can be centralised on a PC using the CONTROL VISION software or another system (PLC for example) via a RS485 link with the JBUS/MODBUS or PROFIBUS protocol.

► Measurement

Whatever the network (single, two and three-phase), the DIRIS measures the current (from 1, 2 or 3 CTs) and the voltage 600 or 700 VAC between phases or above from a VT, allows the calculation of:

- the TRMS values⁽²⁾ of the currents
- the TRMS values⁽²⁾ of the voltages
- the active power (W)
- the reactive power (Q) with the indication of the sign (L for inductive and C for capacitive) and thanks to the following formula: $\sqrt{Q} = S^2 - P^2$
- the apparent power (VA)
- the power factor (FP) with the indication of the sign (L for inductive and C for capacitive) and thanks to the following formula: $FP = P/S$.

The frequency (Hz) will be measured on phase 1 of the network.

► Metering

The metering of active (kWh) and reactive (kvarh) energy is calculated from the active and reactive power. They reflect the consumption of an electrical installation. The COUNTIS is used for active energy metering on 2 quadrants. The DIRIS is used for active and reactive energy metering on 2 or 4 quadrants.

From 1 or 8 ON/OFF inputs, it is possible to count kWh according to an external signal (example: energy supply company clock) or impulses coming from meters (water, gas, electricity, etc.) or other systems (breaking devices, etc.). Moreover, the DIRIS CMv2 provides 8 sub-meters tripped by a start and end date and/or time.

Examples: every day from 8 o'clock to 12 o'clock or from 01/01/99 at 2 o'clock to 01/02/99 at 2 o'clock

The energy is made available on 1 programmable impulse output for the kWh (COUNTIS and DIRIS) and a 2nd programmable impulse output for the kvarh (CM/CMv2 only).

(1) Metering visualises consumption from power on in real time. Management is based on a history of the 10 minute periods.

(2) The TRMS value is also called true RMS. See § disturbance of measuring devices.

► Energy management

Energy management is based on the integration of the active power over a period determined by the energy supplier. In France, this period is 10 minutes and of 15 minutes in Belgium or in Germany. To use this function, it is necessary to use a product capable of integrating this value according to an internal (DIRIS clock) or external (energy supply company signal) synchronisation and to store it (FIFO memory) to avoid there being permanent communication with the centralisation system.

The CM has a memory capacity of 8 days in 10 minute periods and 12 days in 15 minute periods. The CMv2 has a 28 day memory in 10 minute periods and 42 days in 15 minute periods.

The relationship between these values and pricing (see opposite) allows:

- drawing up of a complete tariff report indicating the kWh consumed by tariff-period
- analysis of a load curve
- performance of a tariff simulation function.

Energy management

DIRIS and COUNTIS

Functions and applications (continued)

► Monitoring

The DIRIS system allows alarms to be configured for voltage, current, active power, power factor and frequency (Mh and CMv2).

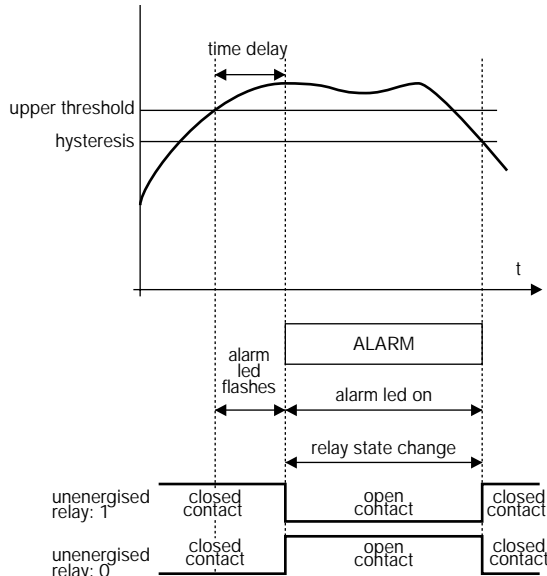

Fig. 1: monitoring of an upper threshold

Each alarm is characterised by the programming of:

- threshold:
The alarm threshold may be an upper threshold (superior: over-voltage, overcurrent, etc.) or a lower threshold (inferior: voltage drop, etc.).

Application

- protection of dangerous machinery in cases of mains undervoltage on the network
- monitoring motor current. An under-current reveals a load modification (belt rupturing...)
- monitoring of a lack of voltage
 - hysteresis
 - time delay
 - break state of the relay:
 - 0: normally open,
 - 1: normally closed.

The normally break closed position provides a positive security alarm: the relay opens if there is a loss of auxiliary power supply to the DIRIS, which corresponds to an alarm.

The normally break open position provides a negative security alarm: the relay closes if there is a loss of auxiliary power supply to the DIRIS, which corresponds to an alarm.

Notes:

For each parameter to be monitored, the DIRIS:

- checks configuration coherence
- stores the three last alarms for each parameter, including:
 - violation duration
 - date and time
 - maximum values reached.

► Control and command

To control and command, it is necessary to be able to drive a set of inputs and outputs. The DIRIS with 2 to 8 input and 2 to 6 output, allows an operator to manage his operations off-site. Indeed, the ON/OFF inputs, connected to auxiliary contacts, transmit the position information (open: closed) and the number of operations (maintenance). The relay outputs will drive a whole series of actuators (load-break switches, contactors...) to shed load from a distribution system or stop a manufacturing process. This remote control system is easily done using an RS485 serial link directly connected to a PC (CONTROL VISION software, for example) or another system (PLC, etc.).

► Communication

See § Communication networks.

Communication: general points

Description

DIRIS and COUNTIS can be connected to any system (PLC, PC, etc.) operating with an RS485 network and JBUS/MODBUS® protocol.

The communication function enables:

- remote value readings measured by the DIRIS system and their processing by a PC or other
- configuration readings (measurements, alarms, etc.)
- remote configuration (transformation ratios, alarms, etc.)

Physical layer: RS485

- 3-wire serial link + earth (see also link installation below)
- Configurable output: 1200, 2400, 4800, 9600, 19200 or 38400 bauds
- Topology: bus network with up to 31 devices on the same link. To connect more than 31 products, RS485 repeaters can be used (please consult us).
- Maximum range: 1500 m to 9600 bauds. For bigger distances, repeaters or RS485 dividers must be used (please consult us).

Link layer

- Operating in master/slave mode:
 - The master (supervisor, PLC, etc.)
 - interrogates or sends a command to each DIRIS or other terminal (slave) which answers or performs the command
 - recognises each slave by identifying it by a number called the address. The address of each DIRIS can be set between 1 and 255.
- The link layer also provides transmitted message control, enabling detection of possible transmission errors.

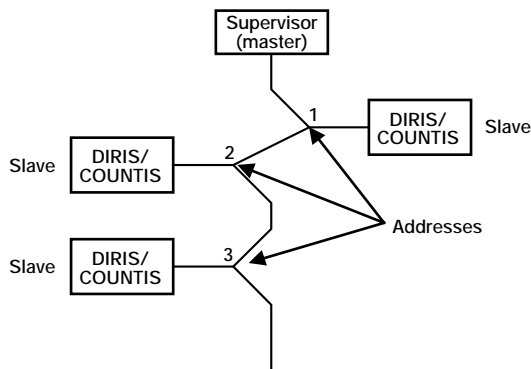

Fig. 1: operation in master/slave mode

Protocol

Jbus/Modbus is used in RTU (Remote Terminal Unit) mode with hexadecimal characters consisting of at least 8 bits. This protocol implies a master-slave dialogue that can operate according to 2 principles:

- the master interrogates a slave and waits for its answer
- the master interrogates all the slaves one after the other without waiting for their answers.

The dialogue is identified as a communication frame. A frame consists of:

Address of the slave	Code of the function	Address of the message	Size of the message CRC16
----------------------	----------------------	------------------------	------------------------------

To exploit the information, our products have 4 functions:

- Function 3: for reading N words (maximum 128 words)
- Function 6: for writing a word
- Function 8: for exchange diagnosis (from meters 1, 3, 4, 5 and 6)
- Function 16: for writing N words.

Connecting the RS485 link

DIRIS and COUNTIS communicate via an EIA 485 (RS485) 3 active wire serial link (L1, L2 and 0 V), with or without shielding.

On the same RS485 link, up to 31 devices can be connected plus the master (PLC or micro-computer) equipped with an RS485 interface.

The number of devices may be increased on a communication network by using repeaters (maximum 255 per communication channel).

We recommend the use of a twisted pair with earth wire. In environments with a high level of interference, use of a 3-wire shielded cable linking the shielding to earth at one end only is advised.

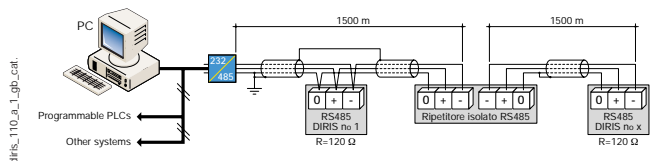
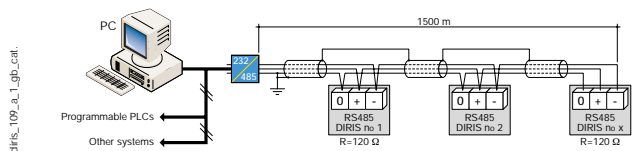

At either end of the RS485 link, it is imperative that there be a resistive load of 120 Ohms integrated into each DIRIS.

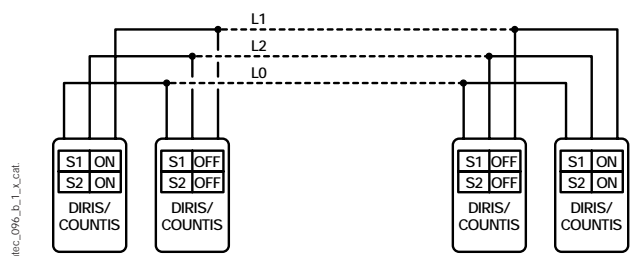

Fig. 3: example of DIRIS connection

We recommend the use of a cable of type:

- LIYCY: 2 twisted pairs with general shielding (min. section 0.34 mm²)
- LIYCY-CY: 2 twisted pairs with shielding of each pair plus general shielding (min. section min. 0.34 mm²)

Note: all the products connected to the same RS485 link must have a different address (JBUS/MODBUS® address).

Energy management

DIRIS and COUNTIS

Communication frame

► DIRIS M addressing table

Information reading (function 3)

ADDRESS IN HEXA.	NUMBER OF WORDS ⁽¹⁾	NAME	UNIT
700	1	0 for a CT with a 1A secondary 1 for a CT with a 5A secondary	A
701	1	current phase 1	0.1 A
703	1	current phase 2	0.1 A
705	1	current phase 3	0.1 A
707	1	current of neutral	0.1 A
709	1	phase to neutral voltage phase 1	0.1 V
70B	1	phase to neutral voltage phase 2	0.1 V
70D	1	phase to neutral voltage phase 3	0.1 V
70F	1	phase to phase voltage U1-2	0.1 V
711	1	phase to phase voltage U2-3	0.1 V
713	1	phase to phase voltage U3-1	0.1 V
715	1	active power	0.1 kW
717	1	reactive power	0.1 kvar
719	1	apparent power	0.1 kVA
71B	1	power factor	/
71D	1	frequency	0.1 Hz
71F	1	I1 max	0.1 A
721	1	I2 max	0.1 A
723	1	I3 max	0.1 A
725	1	P max	0.1 kW
727	1	active energy + (4 upper digits)*	kWh
729	1	active energy + (3 lower digits)*	kWh
72B	1	reactive energy + (4 upper digits)*	kvarh
72D	1	reactive energy + (3 lower digits)*	kvarh
72F	1	active energy (4 upper digits)*	kWh
731	1	active energy (3 lower digits)*	kWh
733	1	reactive energy (4 upper digits)*	kvarh
735	1	reactive energy (3 lower digits)*	kvarh
737	1	sign P 0 =+ and 1 =-	/
738	1	sign Q and PF 0 =+ and 1 =-kvar	/

⁽¹⁾ Size of this zone: 30 words or 1E in hexadecimal (with the 4 quadrant option) - 24 words or 18 in hexadecimal (without the 4 quadrant option)

* position digits on the display

Example

To read 3650 kWh it is necessary to send the following message:

Slave	Function	Address high-order	Address low-order	Number of words high-order	Number of words low-order	CRC 16
05	03	07	27	00	02	74F0

Response of the DIRIS M:

Slave	Function	Number of bytes	Value of high-order	Value of low-order	CRC 16
05	03	04	0003	028A	CF34
			3	650 kWh	

Example

To display all the values in a single interrogation, it is necessary to send the following frame:

Slave	Function	Address high-order	Address low-order	Number of words high-order	Number of words low-order	CRC 16
05	03	07	00	00	1E	C532

Writing of the devices (function 6 or 16)

ADDRESS IN HEXA.	NUMBER OF WORDS ⁽¹⁾	NAME	UNIT
100	1	primary of CT	1 A
102	1	weight of the impulse output	10 Wh
104	1	type of network: 0: 3 Lb 1: 3 Lnb 2: 4 Lb 3: 4 Lnb	/
105	1	frequency 0: 50 Hz and 1: 60 Hz	Hz
106	1	integration time of power	1 minute
107	1	integration time of current	1 minute
108	1	flashing of parameters	500 ms
10A	1	flashing of measurements	500 ms
500	1	reset	/

⁽¹⁾ Size of this zone: 9 words or 9 in hexadecimal

Recommendations

After modification of the parameters, a back-up must be made using the address 500.

Example

Configuration of a 10 A CT primary for the DIRIS number 5:

Slave	Function	Address high-order	Address low-order	Number of words high-order	Number of words low-order	CRC 16
05	06	01	00	00	0A	09B5

Response of the DIRIS M: identical to the message sent.

Measuring

Installation guide

► Ferro-magnetic equipment

This consists of two repelling magnets (one fixed, the other moving and attached to the needle), placed inside a coin supplied by the current to be measured.

Magneto-electric equipment reads the alternating signal rms: waveform influence is negligible. It can also be used on a DC signal, but is detrimental to its accuracy class.

Its simplicity makes it a particularly suitable instrument for measuring alternating currents on LV switchboards.

► Magneto-electric equipment

Measuring current flows through a moving coil placed in a permanent magnet's magnetic field. Under electro-magnetic forces, the coil pivots in proportion to the current value.

With its low consumption, it is an excellent measuring device for low value DC signals.

► Magneto-electric equipment with rectifier

As the moving-coil galvanometer is a DC polarised device, it can measure high AC values by the addition of a diode rectifier.

► Operating position

ROTEX and DIN indicators are calibrated with dials in a vertical position. Use in other positions is possible without noticeable loss of accuracy. Indicators can be calibrated to work in different positions on demand (to be specified when ordering).

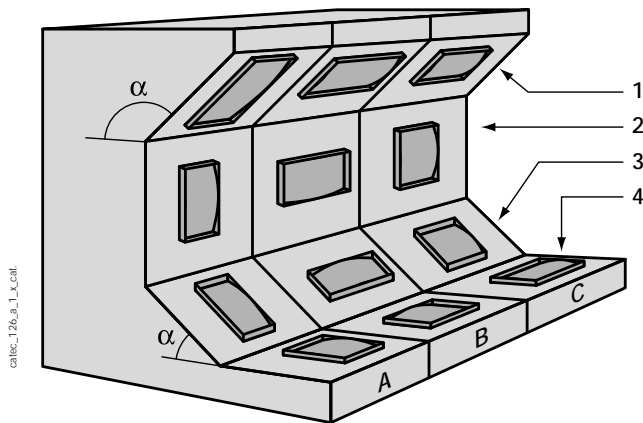

- 1: $\alpha > 90^\circ$
- 2: $\alpha = 90^\circ$
- 3: $\alpha < 90^\circ$
- 4: $\alpha = 0^\circ$

► Use of voltage transformers

- 3 VT circuit: 63 kV mains – VT 63 kV / 100 V / $\sqrt{3}$

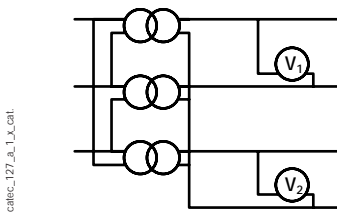

Voltmeter
100 V = 63 kV
measures LV phase
to phase voltage, and
indicates HV phase
to phase voltage

Voltmeter
100 V / $\sqrt{3}$ = 63 kV
measures LV phase
voltage, and indicates
HV phase voltage

- 2 VTs in "V" circuit: 63 kV mains - VT: 63 kV / 100 V
(use: measuring 3 voltage values with 2 VTs)

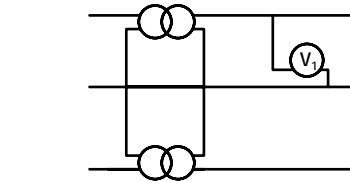

Voltmeter
100 V = 63 kV
measures LV phase
to phase voltage and
indicates HV phase
to phase voltage

► Power converter

Example: calibrating an active power converter:
CT 20 / 5 A, U = 380 V, three-phase mains, $\cos \varphi = 1$
Standard calibration:

$$P' (\text{converter}) = UI \cos \varphi \sqrt{3} = 380 \text{ V} \times 5 \text{ A} \times 1 \times 1.732 = 3290 \text{ W}$$

therefore with a 20 A CT $P = 3290 \text{ W} \times 20 / 5 = 13.16 \text{ kW}$

converter output: 0 mA = 0%; 20 mA = 100% load

- Calibrating for numeric display, threshold relay or BMS (Building Management System): A numeric display can be calibrated to display 13.16 kW at 20 mA, therefore converter calibration is unnecessary.

- Calibrating for needle indicator (scaled from 0 to 15 kW) calibrated at 20 mA at scale lower limit: The associated device is not adjustable, therefore converter calibration will be performed as follows:

$$P' (\text{converter}) = \frac{15 \text{ kW}}{13.16 \text{ kW}} \times 3290 \text{ W} = 3750 \text{ W for 20 mA}$$

$$I' (\text{converter output}) = \frac{13.16 \text{ kW}}{15 \text{ kW}} \times 20 \text{ mA} = 17.55 \text{ mA}$$

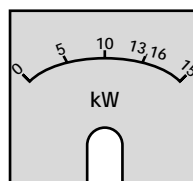

$$3290 \text{ W} \Rightarrow 13.16 \text{ kW} \Rightarrow 17.55 \text{ mA}$$

$$3750 \text{ W} \Rightarrow 15 \text{ kW} \Rightarrow 20 \text{ mA}$$

Measuring

Installation guide (continued)

Accuracy class index

• **Analog measuring devices** are characterised by a class index (or accuracy class). This represents the maximum error expressed in hundredths of the device's highest value.

Example: for an ammeter with 50 divisions, class 1.5 the error will be $\frac{1.5}{100} \times 50$ therefore giving: 0.75 division

- therefore for a 20 A ammeter: $20/50 \times 0.75 = 0.3$ A
- therefore for a 400 A ammeter: $400/50 \times 0.75 = 6$ A

• **Numeric (or digital) devices** can indicate a value of ± 1 unit of the last displayed digit in addition to the true accuracy of the devices components.

Example: A 3 digit indicator (999 points) with 0.5% accuracy, connected to a CT 400/5 A, 400 A display

- (a) intrinsic error $400 \times \frac{0.5}{100} : \pm 2$ A
- (b) display error: 1 digit gives therefore: ± 1 A
- maximum reading values: (a) + (b) = ± 3 A (at nominal load).

• **Current transformers** are characterised by their accuracy class. The error varies according to loads as follows:

		Error (\pm % of I_n)						
LOAD LEVEL		0.1 I_n	0.2 I_n	0.5 I_n	I_n	1.2 I_n	5 I_n	10 I_n
Class	0.5	1.0	0.75		0.5			
	1	2.0	1.50		1.0			
	3			3	3	3		
	5			5	5	5		
	5P5				5		5	
	5P10				5			5

Example: 5P5 CTs are used to measure motor circuit current and guarantee a $\pm 5\%$ accuracy at 5 I_n .

Copper cable losses

Cable losses must be taken into account to define the CT or converter power to be chosen, so as to ensure correct measuring chain functioning.

$$\text{Loss (in VA)} = \frac{I^2 \text{ (in A)} \times 2}{S \text{ (in mm}^2\text{)} \times 56} \times L \text{ (in m)}$$

L: distance between CT and indicator

CABLE LOSS IN VA ⁽¹⁾ For 5 A CT							
L (in m)	1	2	5	10	20	50	100
S (mm ²)							
1.0	0.89	1.79	4.46	8.93	17.9	44.6	89.3
2.5	0.36	0.71	1.79	3.57	7.14	17.9	35.7
4.0	0.22	0.45	1.12	2.23	4.46	11.2	22.3
6.0	0.15	0.30	0.74	1.49	2.98	7.44	14.9
10	0.09	0.18	0.45	0.89	1.79	4.46	8.93

CABLE LOSS IN VA ⁽¹⁾ For 1 A CT							
L (in m)	1	2	5	10	20	50	100
S (mm ²)							
1.0	0.04	0.07	0.18	0.36	0.71	1.79	3.57
2.5	0.01	0.03	0.07	0.14	0.29	0.71	1.43
4.0	-	0.02	0.04	0.09	0.18	0.45	0.89
6.0	-	-	0.03	0.06	0.12	0.30	0.60
10	-	-	0.02	0.04	0.07	0.18	0.36

⁽¹⁾ only the active component of losses is taken into account

Summation transformer

Summation CTs enable rms addition of several AC currents of the same phase. These currents can have different cos. φ .

Summation CTs are defined by:

- the number of CTs to be connected (CTs with the same winding ratio)
- operating nominal power.

Example: 3 circuits to be measured for output onto recorder and indicator:

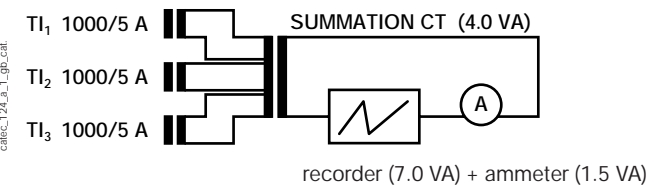

- (a) power balance to be supplied by summation CT: (ammeter + recorder + measuring circuit loss)
 $P' = 1.5 \text{ VA} + 7.0 \text{ VA} + 1.5 \text{ VA} = 10.0 \text{ VA}$
- (b) Power balance to be supplied by CTs:
 $P = P' + \text{summation CT's own consumption}$
 $P = 10.0 \text{ VA} + 4.0 \text{ VA} = 14.0 \text{ VA}$ gives therefore: P/3 per CT

Saturable CT

Saturable CTs ensure power supply to low power thermal relays by protecting them against overcurrent due to frequent motor start-up (saturable CTs are only available with 1 A output).

- SOCOMECC distinguishes between two types of saturable CTs:
- CTs with saturation starting at 4 I_n for normal start-up (e.g. pumps)
 - CTs with saturation starting at 1.5 I_n for abrupt start-up (e.g. flapless fans).

Adapting winding ratios

With nominal currents of less than 50 A it is possible to use CTs with higher primary current, by passing the primary line through the CT several times. Notwithstanding savings, this method enables the different winding ratios to be adapted (constant efficiency and measuring accuracy).

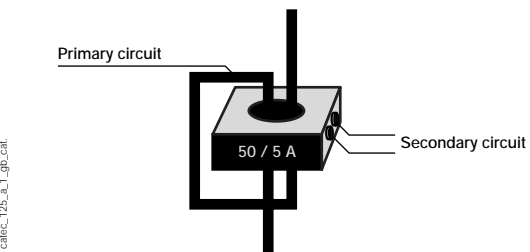

Example: 50 A CT primary circuit.

PRIMARY CURRENT TO BE MEASURED	NUMBER OF PASSES
50 A	1
25 A	2
10 A	5
5 A	10

Differential protection

General points

An earth fault current is a current which flows to earth when there is an insulation fault (I_d). An earth leakage current is a current which flows from the live parts of the installation to earth, in the absence of any insulation fault (I_f).

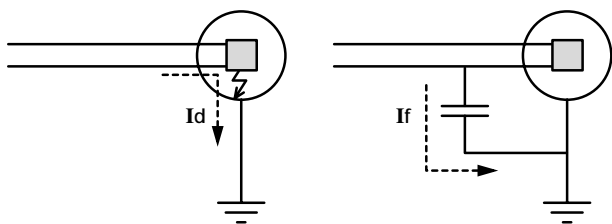

cathec_217_a_1_x_catl

A Residual Current Device (RCD) as defined by IEC 755 is designed to detect earth leakage or fault currents occurring generally downstream of their installation point.

The main types of differential device are:

- differential circuit breakers
- differential switches
- differential relays which are not integrated in the breaking device.

SOCOMEK, a specialised manufacturer, offers a complete range of differential relays which will be able to meet the requirements of every case appropriately.

Differential relays have two purposes:

- **to cut off the installation** when it is associated with a breaking device with automatic tripping
- **signal a leakage** or fault current when it is used as a signalling relay.

► Signalling

Signalling when an earth leakage or fault current is detected and remains at a level nevertheless allowing preventive maintenance work. Differential signalling consists of:

- of a toroid surrounding the live conductors to be monitored which detects the residual current when the sum of the currents on line is no longer zero.
- of a differential current analysis and measuring device which, using its alarm LEDs, its output relays or its digital output will alert the operators.

Certain applications may require both functions, breaking and signalling, at the same time.

► Breaking the installation

Differential protection in this case consists:

- of a toroid surrounding the live conductors of the circuit to be protected which detects the residual current when the sum of the currents on line is no longer zero
- of a differential current analysis and measuring device which issues the alarm signal
- of a supply breaking device which is tripped by the alarm relay.

When a danger appears (electric shock, fire, explosion, malfunctioning of a machine, etc.) an automatic supply breaking device performs one or more of the following functions:

- protection against indirect contacts
- limitation of the leakage currents
- complementary protection against direct contacts
- the protection of the equipment or of the production
- etc.

Differential relays may be combined, in certain conditions, with contactors, circuit breakers or with the switches and fuse switches with tripping in the SIDERMAT and FUSOMAT SOCOMEK range.

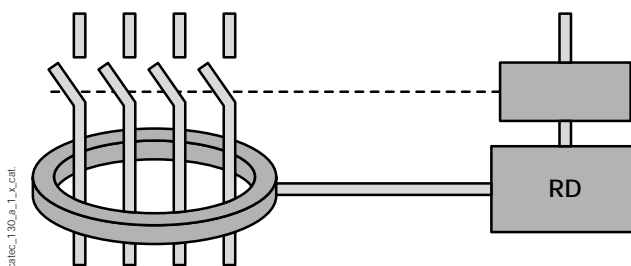

cathec_130_a_1_x_catl

Differential protection

Definitions

▶ Rated residual differential current $I_{\Delta n}$

The rated residual differential current, written as $I_{\Delta n}$, is the differential current's maximum value which must trigger the device's operation. Its value generally expresses the RCD's sensitivity or the setting of the rating (example: RCD 30 mA). An RCD can, from the point of view of the differential product standards, trip with half its rated residual differential current.

SOCOMEK devices, thanks to RMS measurement will be able to bear currents up to 75% (in class AC) of the rated residual current. This level of accuracy allows bigger leakage currents for the same level of protection and thus allows better selectivity.

$I_{\Delta n}$ current values are classified according to three classes of sensitivity:

SENSITIVITY	$I_{\Delta n}$ SETTINGS
LOW SENSITIVITY	20 A
	10 A
	5 A
	3 A
AVERAGE SENSITIVITY	1 A
	500 mA
	300 mA
HIGH SENSITIVITY	100 mA
	≤ 30 mA

▶ Cut-off time

Standard IEC 60755 suggests the following preferential values for maximum cut-off time expressed in seconds for differential devices intended to protect against the electric shocks in the event of indirect contact type faults:

CLASS	I_n (A)	CUT-OFF TIME VALUES		
		$I_{\Delta n}$ s	$2 I_{\Delta n}$ s	$5 I_{\Delta n}$ s
TA	any value	2	0.2	0.04
TB	≤ 40 A only	5	0.3	0.15

Class TB takes into account combinations of a differential relay with a separate breaking device. For protection against indirect contacts, the installation standard IEC 60 364 allows a cut-off time at the most equal to 1s for a distribution circuit, without taking into account the contact voltage if a selectivity is judged necessary. In an end distribution, the differential devices used for the protection of people must be of the instantaneous type.

▶ Classes of differential relays

Standard IEC 60755 defines three utilisation classes for RCDs depending on the type of network:

• class AC

symbol:



example of a fault current:

The device provides tripping with residual differential sinusoidal AC currents.

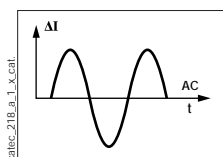

▶ Classes of differential relays (continued)

• class A

symbol:

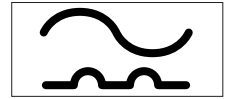

example of a fault current:

The device provides tripping with residual differential, pulsed sinusoidal AC currents whose DC component remains lower than 6 mA during an interval of at least 150° at the rated frequency

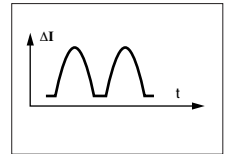

• class B

symbol:



example of a fault current:

The device provides tripping with differential currents identical to the devices in class A but also differential currents coming from rectifier circuits:

- single alternation with capacitive load producing a smooth direct current,
- three-phase simple or double alternation,
- single phase double alternation between phases,
- any that charges an accumulator bank.

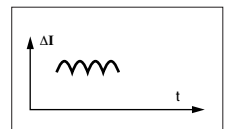

▶ Electromagnetic compatibility (EMC)

The RCD sometimes trip for reasons other than the presence of an insulation fault. The causes are varied: storms, operation of high voltage devices, short-circuit currents, motors starting, fluorescent tubes coming on, closing on capacitive loads, electromagnetic fields, electrostatic discharges.

RCDs with sufficient immunity to these disturbances are spotted by the symbol.

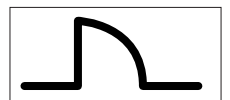

The auxiliary power supplies of SOCOMEK differential relays, strongly immunised, avoid spurious tripping or the destruction of components in the event of overvoltage due to lightning or a HV operation (see opposite).

The principle of measurement by digital sampling of the differential signal and the choice of the toroid materials guarantee good resistance of the differential relays in the event of a wave of transient current occurring on closure of highly capacitive circuits (figure a) or on a disruptive discharge in the event of a dielectric rupture due to an overvoltage (figure b).

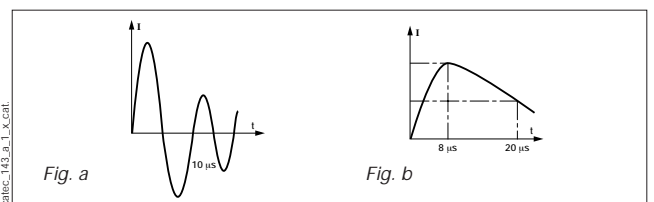
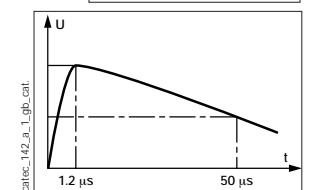

Application

► Protection of an installation

- Total selectivity (vertical selectivity)

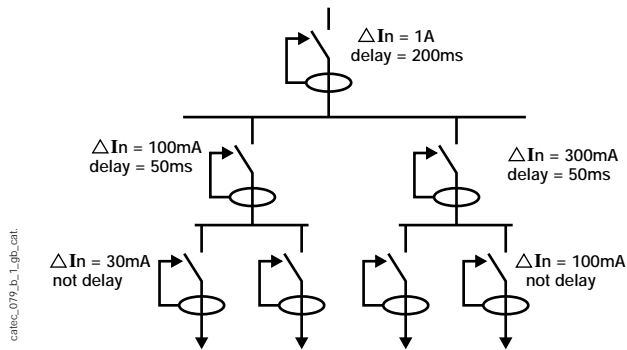

Fig. 1

This is intended to suppress the fault current only in the part of the installation where the fault is to be found. To do this, two conditions must be met:

1. The operating time of the downstream RCD (t_{fB} figure 2) must be smaller than the non-operating time of the upstream device (t_{nfA}). A simple solution to meet this condition consists of using class S RCDs (adjustable delay). Upstream RCD delay must be greater than downstream RCD delay (figure 1).
2. The sensitivity of the downstream RCD ($I_{\Delta n B}$) must be smaller than half of $I_{\Delta n A}$ upstream RCD sensitivity (see figures 1 and 2).

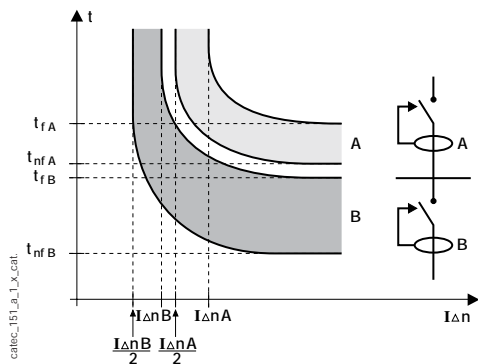
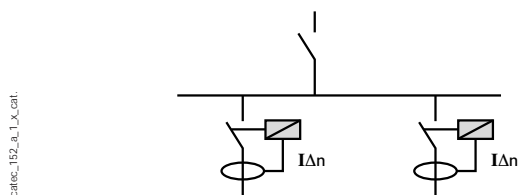

Fig. 2

- Horizontal selectivity

This arrangement consists of placing in certain conditions differential devices that may be of the same ($I_{\Delta n}$) at the same level of a distribution (inside the same panel, an adjacent panel or connected with a type U1000 cable...) without needing to use a general differential device.



With a TT type arrangement, a general differential device is not obligatory upstream of the differential section feeders insofar as all the installation up to the upstream terminals of the latter, complies with the provisions relating to class II or by extra insulation during the installation.

► Protection of motors

An insulation fault that affects the motor coil will have effects that can be classified at two levels:

- destruction of the coil, the motor may be repaired,
- destruction of the magnetic circuit, the motor is destroyed.

The installation of a differential device which limits the fault current to less than 5% of I_n guarantees the non-perforation of the magnetic circuits and saves the motor. As certain large motors may show imbalance between the currents or leakage currents during the start-up phase, it is acceptable to neutralise the differential relay during this phase in certain conditions.

► Leakage current of equipment

Information processing equipment, according to standards EN and IEC 60950, may be a source of leakage current due to the particular filtering devices that are associated with them.

Capacitive leakage currents of 3.5 mA are accepted for power connector circuits and 5% (in certain conditions) for fixed installation circuits. Standard EN 50178 on the Electronic Equipment (EE) used in power installations accepts maximum leakage currents of 3.5 mA AC and 10 mA DC for EE.

In case of these values being exceeded, it is necessary to take complementary measures, such as doubling the protective conductor, cutting off the power supply if the PE is broken off, putting in place a transformer which provides galvanic insulation, etc.

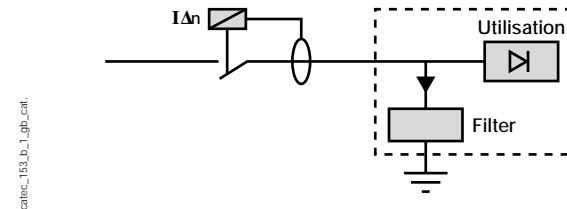
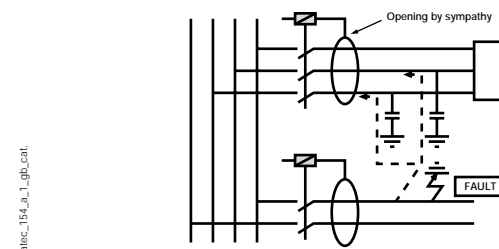

Fig. 1: connection of IMD: general case

► "Sympathy" effect

An important insulation fault affecting a feeder can loop back by the earth leakage capacities of another feeder and cause the latter to trip without there having been any reduction in the insulation of the circuit concerned.

This phenomenon will be particularly frequent on feeders with potentially important earth leakage capacities or when the fault appears in a very long wiring system.



One solution to limit this effect is to delay the differential devices.

► Protection against fire

Paragraph 482.2.10 of standard IEC 60 364 stipulates the use of RCDs at $I_{\Delta n} \leq 500$ mA to protect premises where there is a risk of fire.

Differential protection

Implementation

All installations have an earth leakage current mainly due to the conductors' capacitive leakage and to anti-parasitic or EMC filtering capacitors, for example class I equipment.

The sum of all these leakage currents may cause highly sensitive RCDs to trip (tripping becomes possible from $I_{\Delta n}/2$ ($I_{\Delta n} \times 0.80$ for SOCOMEC RESYS P and M devices) without endangering safety to personnel.

Earth leakage currents may be limited by:

- the use of class II equipment,
- isolating transformers,
- circuits powered by UPS,
- limiting the number of receptors protected by the same RCD.

Improving RCD performance

- Installing to begin with the TT installation. At the origin of TT installation (and only in this case), it is possible to replace the detection toroid placed round live conductors by a single toroid linking the HV/LV transformer neutral to the earth. This arrangement improves immunity to disturbances and has the advantage of being more economical.

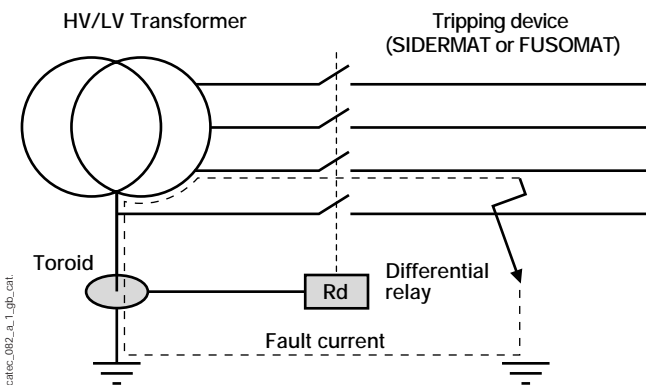

- Increasing immunity to disturbances of a toroid by:
 - symmetrical arrangement of the phase conductors around the neutral conductor
 - using a toroid with a diameter of at least equal to twice that of the circle formed by conductors: $\Delta \geq 2d$
 - possible addition of a magnetic shield, with a height at least equal to $2D$.

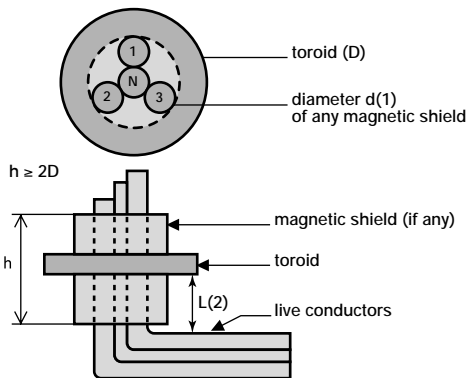

- (1) d = the centering of the cables in a toroid is a guarantee of the local non-saturation of the toroid. A saturated toroid causes spurious trippings.
- (2) L = distance between the toroid and the bend in the cables.

Indication of test conditions of differential devices

Complementary marking should be provided to indicate to the user that the test must be activated regularly (every 3 to 6 months is recommended).

Choice of differential device according to the auxiliary power supply principles

The level of skill of the operators and the destination of the installation will, according to IEC 60 364, determine the choice of the differential protection devices according to the type of operation linked to the power supply principle.

NATURE OF THE DIFFERENTIAL DEVICE	CHOICE POSSIBLE ACCORDING TO THE TYPE OF INSTALLATION	
	UNINFORMED PERSONNEL (BA1)	TRIED AND CHECKED BY PERSONNEL, AT LEAST INFORMED (BA4)
With auxiliary source independent of the network	NO	YES
operating independently of the network voltage	YES	YES
with operation dependent on the network voltage or on any auxiliary source with a fail-safe	NOT recommended	YES
with operation dependent on the network voltage without a fail-safe	NO	YES except circuits PC 16 A
with operation dependent on the network voltage of an auxiliary source without a fail-safe	NO	YES except circuits de PC 16 A and signalling of an aux. source fault

NB: a transformer connected to the network does not constitute an auxiliary source independent of the network.

Characteristics of a differential device with an auxiliary source

- Monitoring independent of the voltage of the circuit monitored
- suited to networks with high and rapid fluctuation
- monitoring independent of the load current (surge of non-balanced currents, coupling of inductive loads)
- better immunity to tripping in case of transient faults (integration time of the order of 30 ns whereas a device with its own current risks tripping in a few ms).

Precautions when installing toroids on armoured cables

- Armoured cable: insulate electrically from the connection box, and connect it to earth.

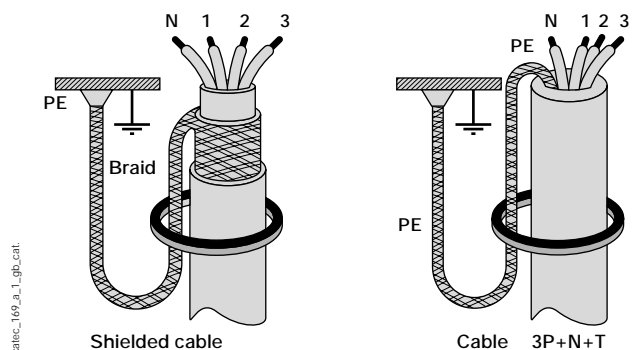

Installation (continued)

► Choice of the class of differential devices according to loads

Equipment is increasingly fitted with rectifying devices (diodes, thyristors,...). Earth fault currents downstream of these devices have a DC component capable of desensitising the RCD.

Differential devices must be of the class suited to the loads (see chapter on definition of classes).

Standard EN 50178 stipulates the following organisational diagram which defines requirements when using EE behind a differential device (EE: electronic equipment).

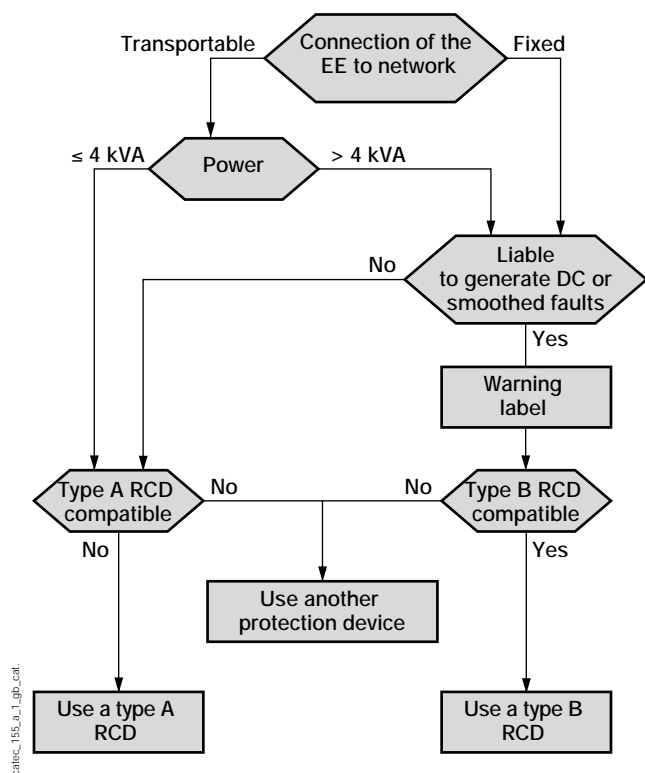

Transportable EE whose rated apparent input power does not exceed 4 kVA, must be designed to be compatible with type A RCDs (protection against direct and indirect contacts).

Any EE which risks generating fault current DC component risking interfering with the operation of the differential protective devices must be accompanied by a warning label which says so.

When the RCDs cannot be compatible with the EE to be protected, other protection measures must be adapted such as: isolating the EE from its environment by double or reinforced insulation, or insulating the EE from the network using a transformer, etc.

► "Industrial" loads

The most common devices are of AC class, but the real situation of industrial installations justifies the use of at least, A class devices.

► Speed variator type loads

As this type of load fluctuates considerably, class B relays, independent of the voltage and current, will be even more particularly suited to prevent risks of spurious tripping.

► Grouping of uses according to the type of load

Installations must group together the types of devices which cause identical faults.

If loads are liable to generate DC components, they must not be connected downstream of devices intended to protect loads generating, in fault, only AC or pulsed rectified components.

► Signalling or pre-alarm of a leakage or fault

In installations where continuity of operation is imperative and where the safety of property and people is particularly at risk, insulation faults constitute a major risk that it is particularly important to take into account.

This signalling function may be performed in two ways:

1. the automatic breaking of the power supply for imperative reasons of protection (protection against direct, indirect contacts, or limiting the leakage current) is provided by differential devices, the signalling function may be provided by the pre-alarm relays which are incorporated in certain differential relays (RESYS M40, P40, B,... of SOCOMEC).
2. the automatic breaking of the power supply for imperative reasons of protection (protection against direct, indirect contacts, or limiting leakage current) is provided by other devices, such as for example overcurrent protection devices. The alarm contact of the relays (RESYS M, P, E... of SOCOMEC) can then be used only to signal a differential current.

Preventive signalling of insulation faults provides infinite possibilities in the optimisation of an electrical installation:

- anticipating a machine repair before the process is stopped or on fault
- locating insulation faults in TNS neutral loads
- preventing risks of fire, explosion, etc.
- anticipating the operation of an overcurrent protection device and thus avoiding the replacement of the fuse or the aging of the circuit breaker
- controlling the leakage currents and thus reducing the homopolar currents in the protection circuits, generating of particularly disturbing electromagnetic fields
- etc.

General points

Introduction

Standard IEC 60 364 impose the use of a permanent Insulation Monitoring Device (IMD) in IT arrangements:

“a permanent insulation monitoring device must be designed to indicate the first occurrence of a live mass or earth fault; it must trigger an audible or visual signal”.

IMDs can also be used in many other applications (see uses on page D.68). SOCOMEC offers a wide choice of IMDs from the ISOM range.

Operating principle

The majority of IMDs inject a measuring current in the loops formed by the live conductors and the earth (fig.1). An increase in measuring current signifies a circuit insulation decrease. Measuring current is compared with the IMD alarm threshold.

Correct IMD operating in the ISOM range does not require a high measuring current.

A 1 kΩ impedance normally added between the circuit to be monitored and the earth (impeding neutral) is practically unnecessary for the SOCOMEC IMDs.

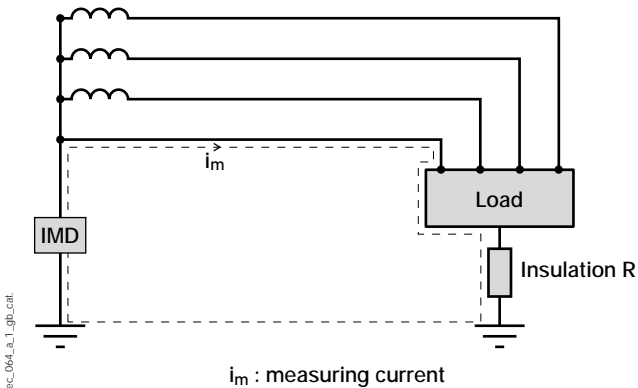
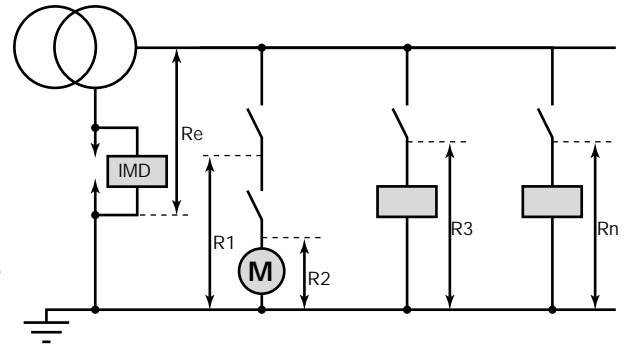

Fig. 1: measurement of an installation's insulation resistance by an IMD

Adjustments

When an IMD is put into service in an installation, account must be taken of the fact that this device is going to measure the overall insulation of the installation, that is the sum of the individual leakage resistances of each feeder.



$$\frac{1}{R_e} = \frac{1}{R_1} + \frac{1}{R_2} + \frac{1}{R_n} \quad (R_1, R_2, R_n \geq 0.5 \text{ M}\Omega)$$

Note: the IMD can indicate a decrease of insulation resistance without there being a dead short fault (presence of humidity after prolonged switching off, for example). Installation start-up will restore the level of insulation (IEC 60 364).

Definitions

► Split network

A split network is characterised by:

- a single receptor or same type receptors (motors, safety lighting...),
- a moderately extended circuit (low earth leakage capacitance) and clearly located circuit (workshop, operating theatre...),
- a well-defined circuit (only AC or DC loads).

► Global network

Conversely, a global network has various receptors and rectifiers (with AC and DC currents). The network is often an extended one (high earth leakage capacitance).

► Asymmetrical fault (DC network)

An asymmetrical fault only affects one of the network's polarities.

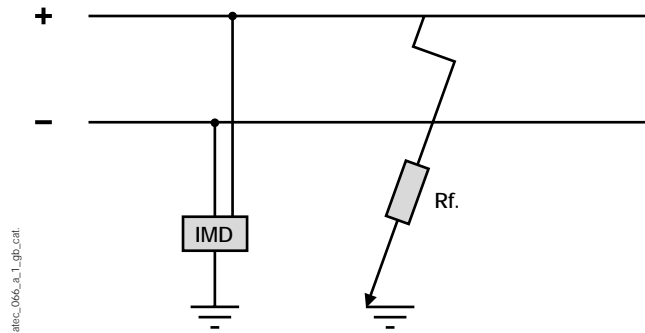

Fig. 1: asymmetrical fault

► Symmetrical fault (network DC)

A symmetrical fault affects both polarities of the network. This type of fault often develops in circuits where the respective lengths of the + and - conductors are comparable.

Since the end of 1997 standards IEC 61557-8 and EN 61557-8 have required that DC circuits be monitored by IMDs capable of detecting symmetrical faults.

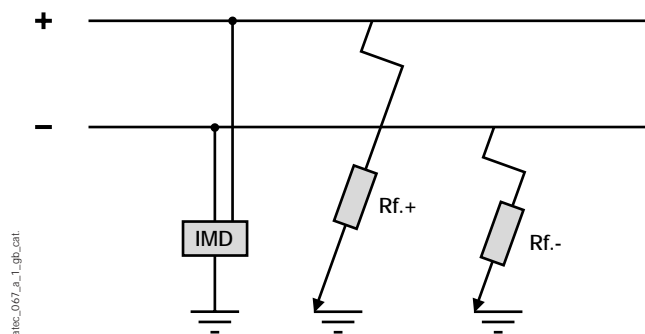

Fig. 2: symmetrical fault

► Insulation resistance of the electrical installation

This is installation's insulation level with regard to the earth. It must be regularly measured by the supervisory agencies and must be greater than the values of standard IEC 60 364.

Table A: Minimum insulation resistance values (IEC 60 364) with power off.

CIRCUIT NOMINAL VOLTAGE (V)	DC TEST VOLTAGE (V)	INSULATION RESISTANCE (MΩ)
TLVS and TLVP	250	≥ 0.25
≤ 500 V	500	≥ 0.5
> 500 V	1000	≥ 1.0

► Receptor insulation

- $R_f \text{ Motor} > 0.5 \text{ M}\Omega$
- $R_f > x \text{ M}\Omega$ according to product standard.

► Conductor earth leakage capacitance

When two conductors have a potential difference (voltage), there is a capacitive effect between them according to their geometric shape (length, shape), to the insulation (air, PVC...) and to the distance between them.

This physical characteristic can trigger a capacitive leakage current between network conductors and the earth. The more extended the network, the higher the current will be.

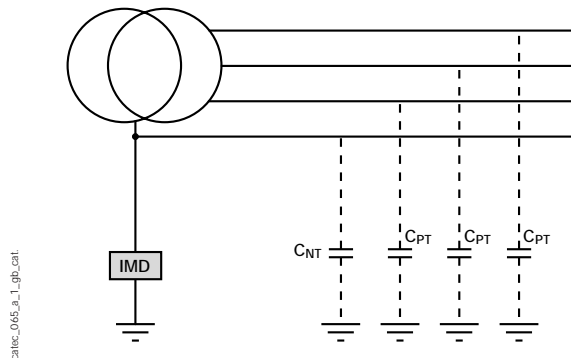
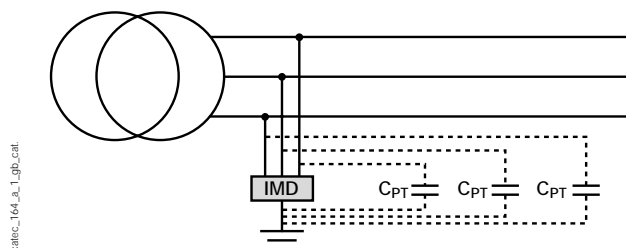

Fig. 2: earth leakage capacitance on an AC network

► Maximum earth leakage capacitance

This is the sum of the network's earth leakage capacitance and of the capacitance of the capacitors installed in the electronic equipment, computer equipment...

Maximum earth leakage capacitance is an important parameter when choosing an IMD. It should be noted that the overall leakage capacitance has considerably increased due to EMC filters.



Example of use

▶ Monitoring the insulation of dead motors (example IMD SP 003)

Monitoring the insulation of dead motors is a preventive measure when equipment safety and availability requirements are obligatory:

- safety equipment: fire fighting motors,
- smoke extractor installations,
- critical cycles in industrial processes,
- strategic or large motors.

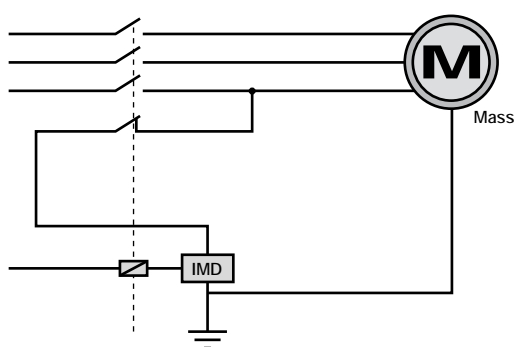

cathec_069_a_1_gb_cat

Fig. 2: assembly principle: the IMD is off circuit when the motor is supplied

Adjustment of the IMD monitoring a dead motor

The IMD must generate an alarm when insulation resistance is less than 1 M Ω (1000 k Ω).

The motor must not be used when insulation resistance is less than 500 k Ω .

Type SP IMDs are specially designed for the monitoring of the insulation with the power off, and are also a means of rapidly locating transient faults thanks to their memory function (examples: points motors, rapid process port cranes).

▶ Monitoring speed variators

The monitoring of speed variators must take into account the low frequencies they generate.

Only IMDs and search devices with measuring principles using coded signals or signals different to those generated by the variators, can, over time, correctly perform their function.

▶ Mobile generator sets

Protecting circuits supplied by mobile generator sets is often difficult to organise because earthing is not possible (portable sets, emergency rescue, etc), or because earthing is not considered valid (resistance impossible to measure, etc.).

This sort of protection is often provided by 30 mA RCDs which has the disadvantage of spurious tripping (see page D.63). In cases where continuous operation is imperative for safety reasons, an IMD may be used (see fig. 3).

The set mass is not linked to the generator mid-point, but to the network consisting of the interconnected masses of the equipment. The IMD is inserted between this mass and a phase.

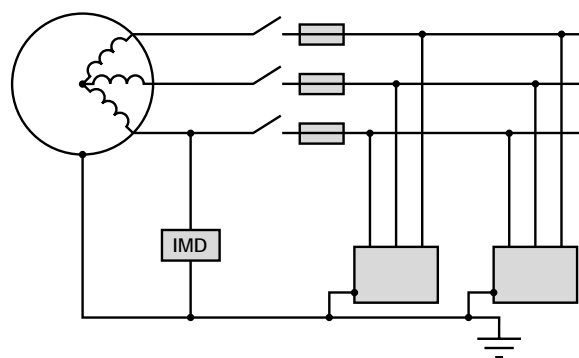

cathec_071_b_1_gb_cat

Fig. 3: use of an IMD for a circuit supplied by generator sets

▶ Monitoring feeders with high disturbance by DLD

Low frequencies

Fault location in this type of circuit is controlled by the synchronisation of the search current injections and the analyses by the locators.

High frequencies

The central locator has measurement validation function by renewing analysis cycles on request.

High homopolar currents

DLD toroids are equipped with levelling diodes controlling potential overvoltages on the secondary.

Examples of use (continued)

► Networks supplied by UPS

Networks supplied by UPS

Static Uninterruptible Power Supply systems comprise a DC component.

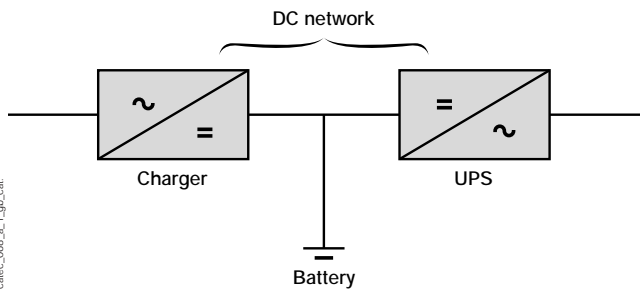
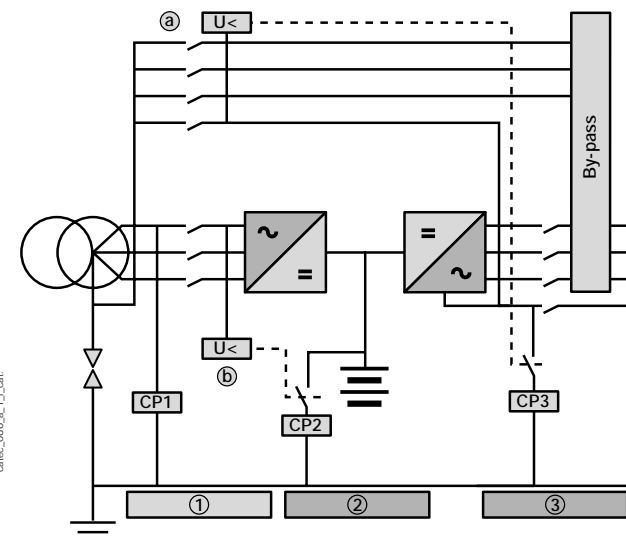

Fig. 3: IMD on network supplied by UPS

It is required that the installation supplied by DC current be grouped together in the same area so as to ensure protection of masses by equipotentiality. When it is not possible to apply this requirement, an IMD must be installed to monitor the installation's correct insulation when supplied by DC current.

Other general criteria for UPS installation

- not having, at the same time, two IMDs monitoring networks that are galvanically interconnected (particularly in the by-pass phases)
- providing for the installation of an IMD adapted to the network monitored.



1. IMD which can monitor circuits with DC components and high leakage capacitances.
2. IMD which can monitor DC circuits with symmetrical faults.
3. IMD which can monitor AC circuits, note (a) and (b), control system avoiding the use of IMDs in parallel on networks not galvanically insulated.

► Monitoring of control and signalling circuits

These circuits, generally supplied by isolating transformers, must ensure non-spurious tripping of power circuits. A common solution, proposed by standards and regulations is to have a wiring system with a TN arrangement (common point coil linked to earth). Another possibility meets these requirements by integrating the secondary's non-connection to earth combined with an IMD.

This solution presents shunting risks on actuators due to an insulation fault. This fault may be both sufficient for controlling actuators and too weak to trip an overcurrent protection.

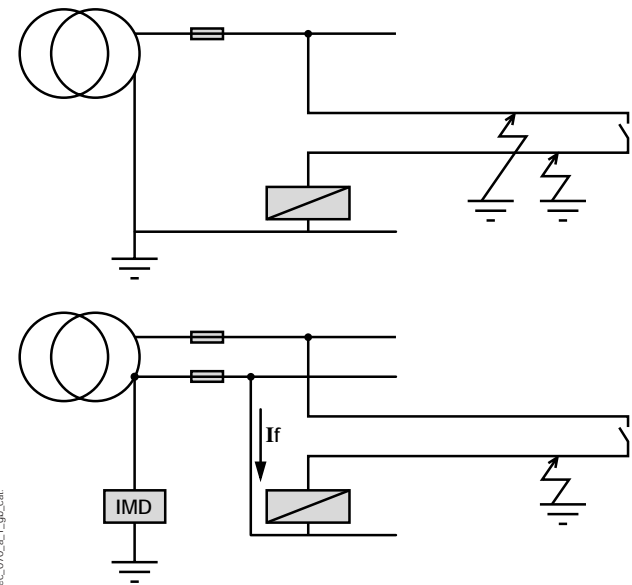

Fig. 1: monitoring insulation on control circuits

These risks are greater on new equipment for two main reasons:

- operating voltages are low and do not facilitate fault detection
- control auxiliaries' operating thresholds are increasingly sensitive, to a few tens of mA (micro-relay, PLCs, optocouplers, etc).

Compared to an earthed solution, using an insulated network linked to an IMD offers the double advantage of not tripping at the first fault, and providing preventive monitoring of equipment ageing.

IMD adjustment

$$Z_m = \frac{U}{I_r}$$

U : control circuit maximum supply voltage.

I_r : smallest relay dropout current.

Z_m : IMD adjustment impedance.

Fault search systems such as DLD204 and the portable DLD3204 system allow preventive location of insulation faults, without changing the status of the actuators or operating controls thanks to a search current limited to 1mA.

IMD connection

► General case

Connecting an IMD is normally done between the transformer neutral point located at the IT installation origin and the earth. The installation must have an alarm device and an overvoltage protection (if HV/LV transformer). Using ISOM IMDs does not require an impedance of 1 kΩ in parallel (see operating principle page D.66).

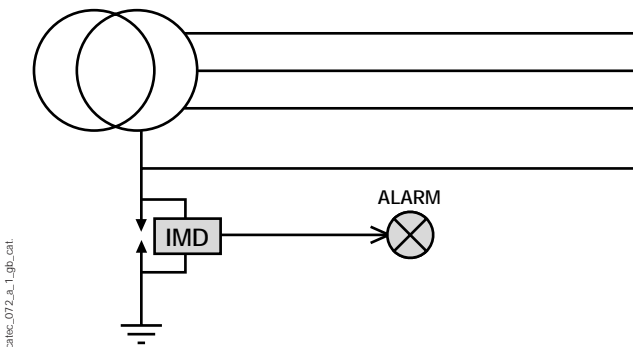

Fig. 1: IMD connection: general case

► Power supply by several transformers in parallel

- If transformers are always designed to operate in parallel, one IMD is enough
- If the transformers can operate independently of each other, each transformer must be equipped with an IMD (see figure below), and a control system that prevents both IMDs from operating when the networks are coupled must also be installed.

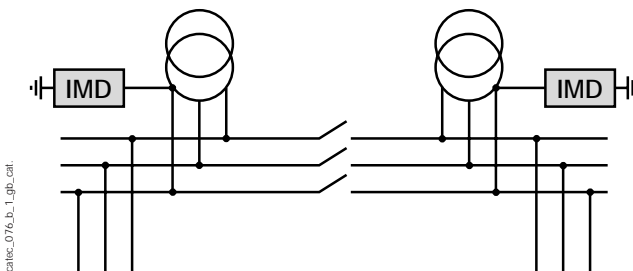

Fig. 6: several transformers in parallel

► Monitoring a dead network

Using an artificial neutral

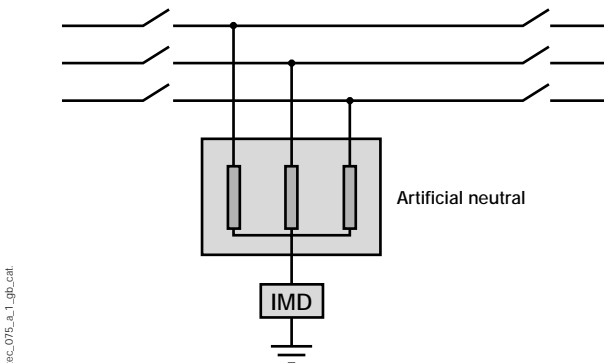

Fig. 5: monitoring of a dead network

► Connection and protection of IMD measuring circuits

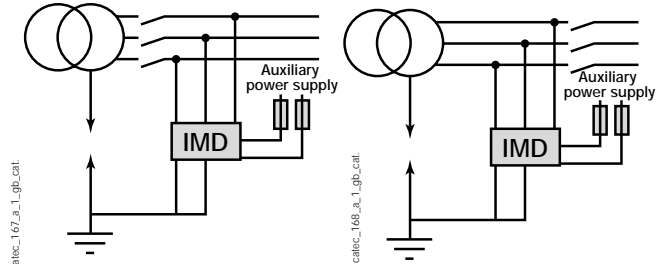

Fig. 3: IMD connection after the master switch

Fig. 4: IMD connection before the master switch

Protection against short circuits is currently not permitted by IEC 60 364 in order to avoid a risk of non-measurement, but supposes an appropriate installation to avoid short circuit risks (no passing of conductors over sharp busbar edges and over insulated conductors). Self-monitoring of the network connection of most SOCOMEC IMDs makes the above provision unnecessary.

- connection of the IMD before the transformer coupling switch, avoids control systems between IMDs where the networks are coupled (fig. 4),
- connection of the IMD after the transformer coupling switch, allows preventive measurement on the dead network (measuring signal present on the phases and not requiring looping via the transformer windings) (fig. 3).

► Neutral accessibility

In this case, the IMD is inserted between the transformer neutral and the nearest mass earth connection or if not the neutral earth connection.

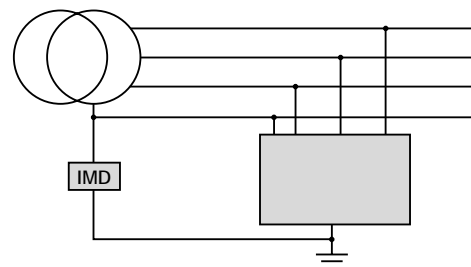

Fig. 2: IMD connection: inaccessible earth

This type of connection also avoids the installation of protection on the measuring conductor in IMD (short circuit-type overcurrents being improbable).

► Auxiliary power supply connection

Certain IMDs have an auxiliary power supply. This makes them insensitive to voltage variations. The auxiliary power supply inputs must be protected:

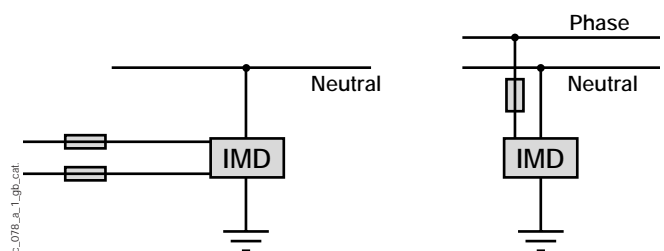

Fig. 7: auxiliary power supply connection

Enclosures

Thermal effects

▶ Device power dissipation

Nominal powers are given for Ith current (nominal rating in the table below).

For the device's operational current:

$$P = P_N \times \left[\frac{I_e}{I_{th}} \right]^2$$

P: power dissipation in W.
PN: nominal power dissipation in W (see table below).
Ie: device's operational current
Ith: device rating.

▶ Thermal characteristics

Calculation of temperature rise

$$\Delta\Delta T \text{ (}^\circ\text{K)} = \frac{P \text{ (W)}}{K \times S \text{ (m}^2\text{)}}$$

P: power dissipation inside enclosure (equipment, connections, cables, etc.).
ΔT: temperature rise in °K.
S: enclosure surface area (not counting surfaces in contact with walls or other obstacles).
K: heat exchange coefficient.
K = 4 W/m² °C for polyester enclosures.
K = 5.5 W/m² °C for metal enclosures.

When the cubicle or enclosures are fitted with air admission, apply standard IEC 890 for the calculation, or consult us.

Calculating ventilation

Where there is forced ventilation, the air flow necessary D is:

$$D \text{ (m}^3\text{/h)} = 3.1 \times \left[\frac{P}{\Delta T} - (K \times S) \right]$$

Ventilators are offered as accessories in the CADRYs range.

Heating resistor determination

This is necessary when interior condensation must be avoided inside the enclosure. The resistor power Pc is given by:

$$P_c \text{ (W)} = (\Delta T \times K \times S) - P$$

Heating resistor powers offered in the CADRYs range are:
 15 W - 30 W - 45 W - 75 W e 150 W.

Air/air exchanger determination: see page D.72

Air conditioning determination: see page D.72.

▶ Example

A cubicle consists of a master switch (FUSERBLOC 4 x 630 A) and several cable leadouts. Nominal current is 550 A.

- Power dissipation at 630 A (table below): $97.7 \times 3 = 293 \text{ W}$
- Power dissipation at 550 A: $293 \times \left[\frac{550}{630} \right]^2 = 223 \text{ W}$

Total power in the cubicle (equipment, cables, etc.) reaches 400 W. Cubicle dimensions: H = 2000 mm, D = 600 mm, L = 800 mm.

The cubicle is placed between two others and against a wall.

The free surface area is:

$$S \text{ (m}^2\text{)} = 2 \times 0.8 \text{ (front)} + 0.6 \times 0.8 \text{ (top)} = 2.08 \text{ m}^2$$

- Temperature rise in cubicle:

$$\Delta T = \frac{400 \text{ W}}{5.5 \times 2.08 \text{ m}^2} = 35 \text{ }^\circ\text{C}$$

For an ambient temperature of 35 °C, the following is obtained:

$$T = 35 \text{ }^\circ\text{C} + 35 \text{ }^\circ\text{C} = 70 \text{ }^\circ\text{C}$$

To maintain a maximum temperature T of 55 °C (ΔT = 20 °C), the following ventilation flow is necessary:

$$D = 3.1 \times \left[\frac{400}{20} - 5.5 \times 2.08 \right] = 26.5 \text{ m}^3\text{/h}$$

▶ Polyester enclosures

These enclosures can be used in public buildings. The French ministerial decree of 25.06.80 requires auto-extinguishing casings (resistant up to 750 °C minimum with glowing wire according to NF C 20-445).

ENCLOSURE TYPE	COMBIESTER COVER		MINIPOL	MAXIPOL
	TRANSPARENT	OPAQUE		
Glowing wire withstand	960 °C	850 °C	960 °C	960 °C

▶ Protection against thermal effects

(According to IEC 60 364)

To avoid any risks due to thermal effects during normal service (fire, burns, overheating), the following can be used:

- differential devices in TT and TN arrangements
- Insulation Monitoring Devices in IT arrangements

Furthermore, the temperature of electrical equipment is limited to the values in the table below:

ACCESSIBLE COMPONENTS	MATERIAL	Max. temp.(°)
Manual controls	Metallic	55
	Non-metallic	65
Parts designed to be touched but not held	Metallic	70
	Non-metallic	80
Parts not designed to be touched during normal service	Metallic	80
	Non-metallic	90

Power dissipation in W/pole for each piece of equipment

Ratings (A)	32	40	50	63	80	100	125	160	200	250	315	400	500	630	800	1000	1250	1600	1800	2000	2500	3150	4000
SIRCO	-	0.6	-	2	2.6	3	1.8	3	4	5.8	7.6	10.8	16	30.9	39.2	45	85	122	153	178	255	444	916
SIRCO VM	0.9	1.3	-	1.2	2.1	3.1	5.7	3.3	5.8	-	-	-	-	-	-	-	-	-	-	-	-	-	-
SIDER	-	-	1	-	2.9	-	1.5	-	3.4	-	-	12.9	17	20.7	32	-	42.5	102	-	-	-	-	-
SIDERMAT	-	-	-	-	-	-	-	-	-	8.2	-	15.6	-	45	66.4	-	80	113	-	-	-	-	-
FUSERBLOC	4.7 (CD)	-	7.3	9	-	14.5	20	23	25.4	41	-	60	-	100	143.4	-	215	-	-	-	-	-	-
FUSOMAT	-	-	-	-	-	-	-	-	-	30.3	-	50	-	83.5	-	-	222	-	-	-	-	-	-

Thermal calculation of enclosures

Hypothesis

- Define the maximum internal temperature at the enclosure, which is imposed by the most sensitive component
- Define the maximum internal temperature of the ambient air (outside the cubicle)
- Define the enclosure dimensions
 where T_i (°C) = Internal temperature
 T_a (°C) = Ambient temperature
 $H - L - P$ (m) = Height - Width - Depth

Power contributed by the components

SOCOMEQ Equipment

See detail of dissipated powers at nominal current (page D.71).

$$P_d = P_{nom} \times \left[\frac{I_e}{I_{th}} \right]^2$$

Where P_{nom} (W): Nominal power
 P_d (W): Power dissipation at operational current
 I_e (A): Operational current
 I_{th} (A): Nominal current

Corrected exchange surface

- Define the correction factor K_n (depends on the method of installation)

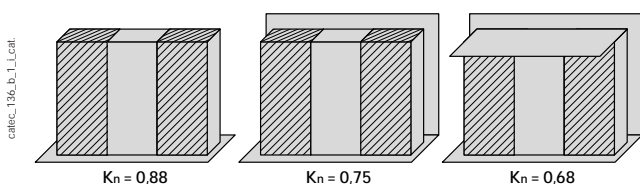
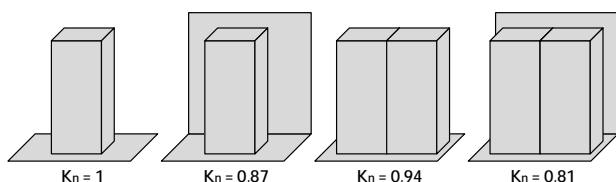

- Corrected surface area

$$S = K_n (1.8 \times H \times (L + P) + 1.4 \times L \times P)$$

Power necessary to maintain the temperature in the enclosure

$$P_n \text{ (W)} = P_d - K \times S \times (T_i \text{ max} - T_a \text{ max})$$

Where $K = 5.5 \text{ W/m}^2 \text{ }^\circ\text{C}$ for a painted sheet metal enclosure
 $K = 4 \text{ W/m}^2 \text{ }^\circ\text{C}$ for a polyester enclosure
 $K = 3.7 \text{ W/m}^2 \text{ }^\circ\text{C}$ for a stainless steel enclosure
 $K = 12 \text{ W/m}^2 \text{ }^\circ\text{C}$ for an aluminium enclosure
 P_n (W): Power necessary

Choice of adjustment method

a) Ventilation

Choose the ventilator whose flow is just above the value calculated.

Note: this solution is only possible if $T_i \text{ max} - T_a \text{ max} > 5 \text{ }^\circ\text{C}$

$$\text{Flow (m}^3\text{/h)} = \frac{3.1 \times P_n}{T_i \text{ max} - T_a \text{ max}}$$

b) Air/air exchanger

Choose the exchanger whose specific power is just above the value calculated.

Note: this solution is only possible if $T_i \text{ max} - T_a \text{ max} > 5 \text{ }^\circ\text{C}$

$$\text{Specific power (W/ }^\circ\text{K)} = \frac{P_n}{T_i \text{ max} - T_a \text{ max}}$$

c) Air conditioner

Choose the air conditioner whose refrigerating power is just above the power necessary (P_n). See table p. D.71.

d) Heating resistor

Choose the heating resistor whose power is just above the value calculated.

$$P_c \text{ (W)} = [(T_i \text{ max} - T_a \text{ max}) \times K \times S] - P_n$$

Busbars

► Choosing bar material

Table A: physical constants of copper and aluminium

	COPPER	ALUMINIUM
Standards	C31-510 and A51-434	C31-520, HN 63 J 60, CNET 3072-1. quality 6101T5
Type	Semi-hard	Alloy Al Mg If tin-plated 15 µm
Apparent density	8890 kg/m ³	2700 kg/m ³
Linear expansion coefficient	17 x 10 ⁻⁶ per °C (17 x 10 ³ mm/m)	23 x 10 ⁻⁶ per °C (23 x 10 ³ mm/m)
Minimum resistance to fracture	250 N/mm ²	150 N/mm ²
Resistivity at 20 °C	≤ 18 MΩ mm ² /m	≤ 30 MΩ mm ² /m
Elastic modulus	120 000 N/mm ²	67 000 N/mm ²

► Determination of peak I_{sc} according to rms I_{sc}

Table B

According to EN 60439-1

RMS VALUES OF SHORT CIRCUIT CURRENT	n
$I \leq 5$ kA	1.5
5 kA < $I \leq 10$ kA	1.7
10 kA < $I \leq 20$ kA	2
20 kA < $I \leq 50$ kA	2.1
50 kA < I	2.2

$$Peak I_{sc} = n \times rms I_{sc}$$

► Thermal effect of short circuit

Short circuit currents cause the busbar temperature rise. The busbar's final temperature must be lower than 160 °C so as not to damage the busbar support. The thermal constraints must be such that:

$$(I_{sc})^2 \times t \leq K_E^2 S^2$$

I_{sc} : rms short circuit current in A

t : short circuit duration (generally equal to protection device operating time).

S : busbar section in mm²

K_E : coefficient given in table C in relation to busbar temperature T_f in normal operating conditions (before short circuit).

Table C

T_f	40	50	60	70	80	90	100	110	120	130
K_E	134.1	127.3	120.4	113.3	106	98.4	90.4	82	72.8	62.6

► Electrochemical coupling

To avoid excessive temperature rise due to electrochemical coupling (corrosion), connecting conductors having electrochemical potentials greater than 300 mV must be avoided (see table D).

Example:

An aluminium busbar cannot be directly connected to a copper busbar. Therefore, inserting a tin-plated aluminium busbar is necessary:

- Alu/Tin → YES
- Tin/Copper → YES

Table D

	SILVER	COPPER	ALUMINIUM	TIN	STEEL	BRASS	NICKEL
SILVER	YES	YES	NO	NO	NO	YES	YES
COPPER	YES	YES	NO	YES	NO	YES	YES
ALUMINIUM	NO	NO	YES	YES	YES	NO	NO
TIN	NO	YES	YES	YES	YES	YES	NO
STEEL	NO	NO	YES	YES	YES	NO	NO
BRASS	YES	YES	NO	YES	NO	YES	YES
NICKEL	YES	YES	NO	NO	NO	YES	YES